

STW-V
1.5t/3.0t/5.0t



STW-V Steel jacks acc. to DIN 7355 with adjustable lifting claw

Capacity 1500 - 10000 kg

The design of the steel jack allows for loads to be picked up and lowered from different heights over the entire length of the steel jack.

The adjustable claw is simply set to the appropriate application height in the load bar for this purpose.

Features

- The claw can be moved to any position on the adjusting rail.
- The load is supported either on the claw or the head of the steel jack.
- Robust base plate for a high level of stability.
- No reduction of capacity on the claw.

STW-V 10.0t

Technical data STW-V Siku

Model	Art.-No. Siku	Capacity kg	Height A mm	Lift ¹ mm	Hand effort at WLL daN	Weight kg
STW-V 15	N01905000	1500	725	350	28	17
STW-V 30	N01905001	3000	725	350	28	23
STW-V 50	N01905002	5000	725	300	28	29
STW-V 100	N01905003	10000	792	300	40	46

¹Height of lift = Height + Lift

Technical data STW-V Raku

Model	Art.-No. Raku	Capacity kg	Height A mm	Lift ¹ mm	Hand effort at WLL daN	Weight kg
STW-V 15	N01905004	1500	725	350	28	17
STW-V 30	N01905005	3000	725	350	28	23
STW-V 50	N01905006	5000	725	300	28	29
STW-V 100	N01905007	10000	792	300	40	46

¹Height of lift = Height + Lift

INFO

STW-V Sifeku on request.

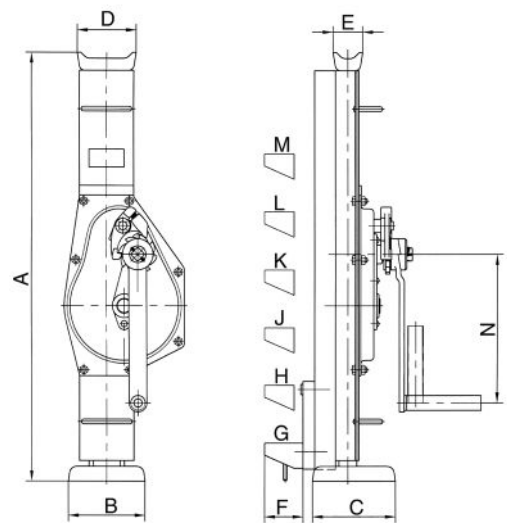

Dimensions STW-V

Model	STW-V 15	STW-V 30	STW-V 50	STW-V 100
A, mm	725	725	725	800
B, mm	130	130	140	140
C, mm	140	140	160	160
D, mm	90	100	110	140
E, mm	50	50	68	76
F, mm	70	70	70	70
G, mm	80	80	80	85
H, mm				191
J, mm	Claw freely adjustable on load bar (55 mm steps)			297
K, mm				403
L, mm				509
M, mm				615
N, mm	250	250	250	300