



## Yale VS III

### Hand chain hoist

#### Capacity 250 - 5000 kg

Extremely low overall height allows optimal use of available headroom. Fully enclosed stamped steel housing allows also outdoor use. The improved hand chain guide prevents canting or jamming of the hand chain, leading to a smooth running of the chain. High quality bearings on side plates, gearbox and load chain sheave ensure smooth operation of load chain and drive pinion. Optimized hand forces set standards for easy operation. The hooks are equipped with robust safety latches and can rotate 360°.

#### Features

- Strong bolts between side plates and housing cover and the reinforced hand wheel cover ensure increased stability.
- Precision machined guide rollers ensure smooth running of the load chain.
- High quality bearings for gearbox, side plates and load chain sheave permit a long service life.
- Zinc-plated and yellow-chromated brake parts and guide rollers ensure increased corrosion protection.
- Zinc-plated load chain as standard for added corrosion protection.

#### Optional

- Overload protection device (from 500 kg available)
- Chain container



Load chain sheave with needle bearing

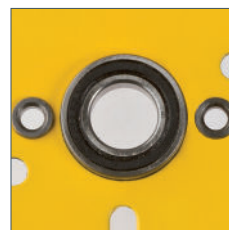

Side plate with ball bearing

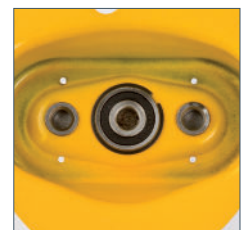

Housing cover with ball bearing

# Yale VS III

## Hand chain hoist

### Capacity 10000 - 50000 kg

Having long years of experience with this solid product, we decided to extend the VS III series by the load capacities 10 t, 20 t, 30 t and 50 t.

In order to serve all industries (even the paper- or the ship industry), the VS III lifts the loads very sensitively, as the components and construction parts have been positioned very precisely.

### Features

- Strong bolts between side plates and housing cover and the reinforced hand wheel cover ensure increased stability.
- Precision machined guide rollers ensure smooth running of the load chain.
- High quality bearings for gearbox, side plates and load chain sheave permit a long service life.
- Zinc-plated and yellow-chromated brake parts and guide rollers ensure increased corrosion protection.
- Zinc-plated load chain as standard for added corrosion protection.

### Optional

- Overload protection device
- Chain container on request



SERIES EXTENSION  
**NOW WITH HIGH SWL!**  
 30000 - 50000 kg

## INFO

To avoid bruising or injuries, the chain inlet as well as the top hook connection is covered in protective material.

## Technical data VSIII

Model	Art.-No.	Capacity in kg/ Number of chain falls	Chain dimensions d x p in mm/ design	Lift per 1 m hand chain overhaul mm	Handle pull at WLL daN	Weight at standard lift (3 m) kg
VSIII 0,25/1	N04200123	250/1	4 x 12 - T	50	20	4.9
VSIII 0,5/1	N04200124	500/1	5 x 15 - T	26	21	9.0
VSIII 1,0/1	N04200125	1000/1	6 x 18 - T	24	24	11.5
VSIII 1,5/1	N04200134	1500/1	8 x 24 - T	17	30	17.5
VSIII 2,0/1	N04200126	2000/1	8 x 24 - T	19	32	19.0
VSIII 2,0/2	N04200127	2000/2	6 x 18 - T	15	29	17.3
VSIII 3,0/1	N04200128	3000/1	10 x 30 - T	12	40	31.0
VSIII 3,0/2	N04200129	3000/2	8 x 24 - T	10	37	27.0
VSIII 5,0/2	N04200130	5000/2	10 x 30 - T	8	41	43.0
VSIII 10/4	192039383	10000/4	10 x 30 - T	2.84	37	78.5
VSIII 20/8	192039384	20000/8	10 x 30 - T	1.42	44.5	197
VSIII 30/12	192039385	30000/12	10 x 30 - T	0.83	46.3	268
VSIII 50/18	192039386	50000/18	10 x 30 - T	0.56	53.6	540

## Dimensions VSIII

Model	VSIII 0,25/1	VSIII 0,5/1	VSIII 1,0/1	VSIII 1,5/1	VSIII 2,0/1	VSIII 2,0/2	VSIII 3,0/1	VSIII 3,0/2	VSIII 5,0/2	VSIII 10/4	VSIII 20/8	VSIII 30/12	VSIII 50/18
A min., mm	290	350	380	450	460	490	570	580	700	860	950	1112	1700
B, mm	12	21	27	33	37	37	46	46	56	63	90	90	165
C, mm	26	28	32	37	41	41	44	44	50	65	86	85	135
D, mm	11	16	19	22	27	27	31	31	37	47	69	67	108
E, mm	118	145	158	180	205	170	240	220	250	463	860	704	776
F, mm	113	140	155	175	180	155	210	175	190	104	200	410	627
G, mm	65	80	87	85	94	87	110	94	95	55	100	225	314
H, mm	48	60	68	90	86	68	100	81	95	50	100	186	314
K, mm	190	240	270	300	320	285	370	340	410	448	508	528	656

## INFO

Yale hoists and trolleys are not designed for passenger elevation applications and must not be used for this purpose.



Optional: Chain container

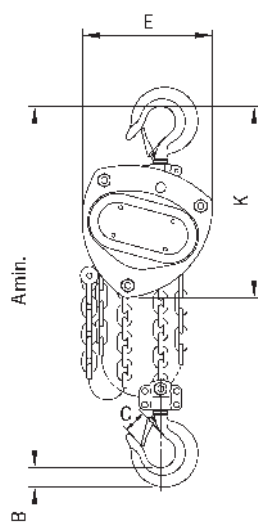

VSIII, 250 - 3000 kg, single fall

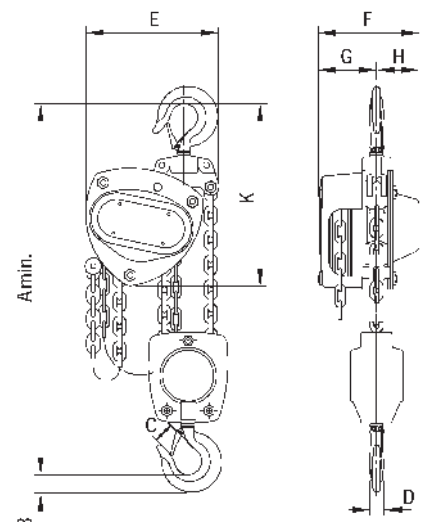

VSIII, 2000 - 5000 kg, double fall

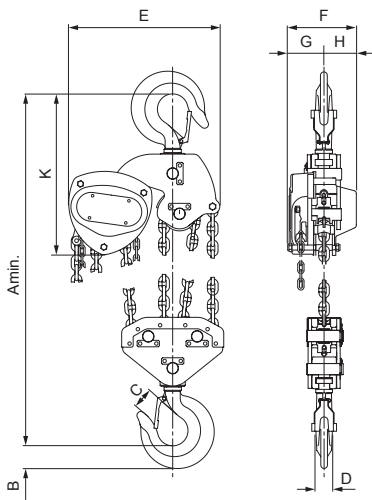

VS/III, 10000 kg, four chain falls

INFO

HTG trolleys for hand chain hoists upwards 10000 kg please see pages 54 - 57.

SERIES EXTENSION  
**NOW WITH HIGH SWL!**  
 30000 - 50000 kg

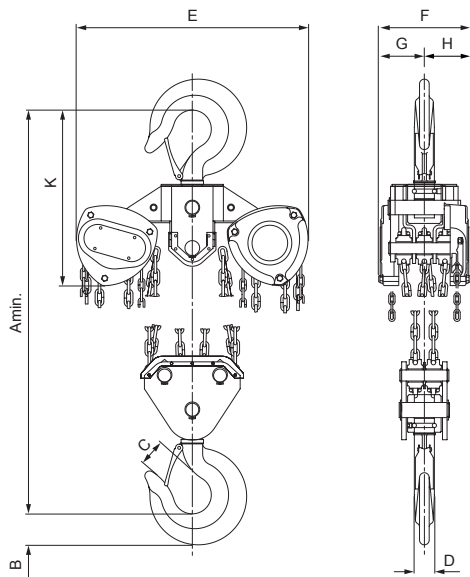

VS/III, 20000 kg, eight chain falls

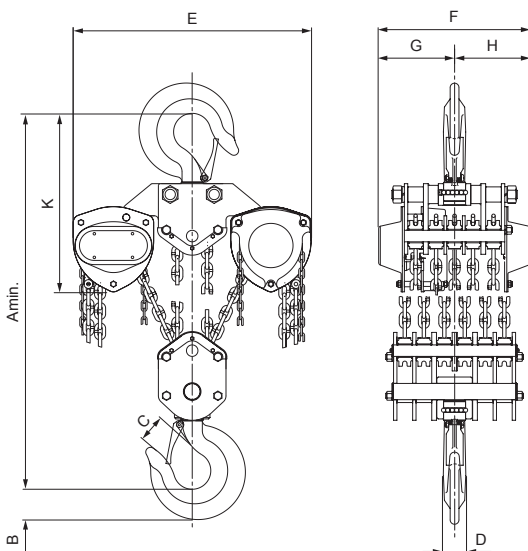
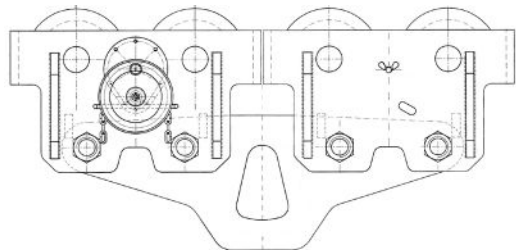

VS/III, 30000 kg, twelve chain falls

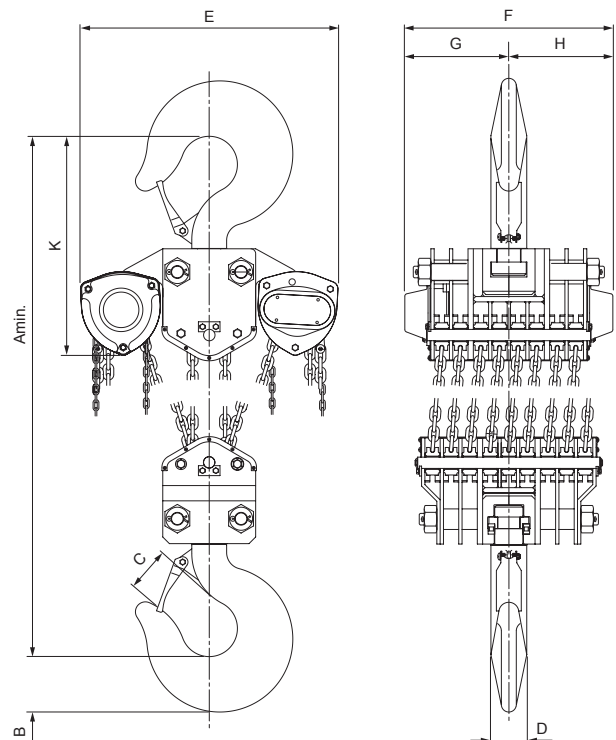

VS/III, 50000 kg, eighteen chain falls