

Yale PUL-LIFT

Ratchet Lever Hoist

Mod. C85 with Roller Chain
Mod. D85 with Link Chain

Capacity 750 kg - 10000 kg

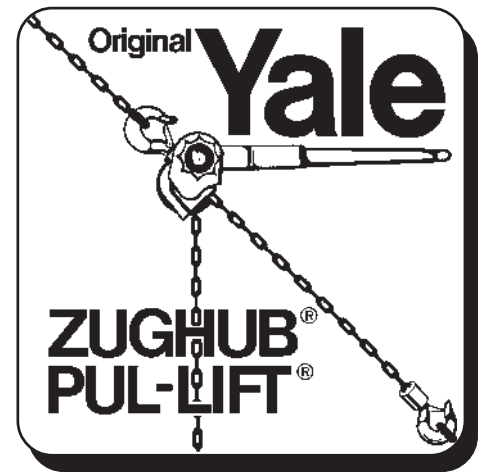

Operating and Maintenance Manual

Spare Parts Catalog

Yale®

Yale Industrial Products GmbH

P. O. Box 10 13 24 • D-42513 Velbert, Germany
Am Lindenkamp 31 • D-42549 Velbert, Germany
Tel. 20 51-600-0 • Fax 20 51-600-127

Yale PUL-LIFT Ratchet Lever Hoist Mod. C/D85

Technical Information:

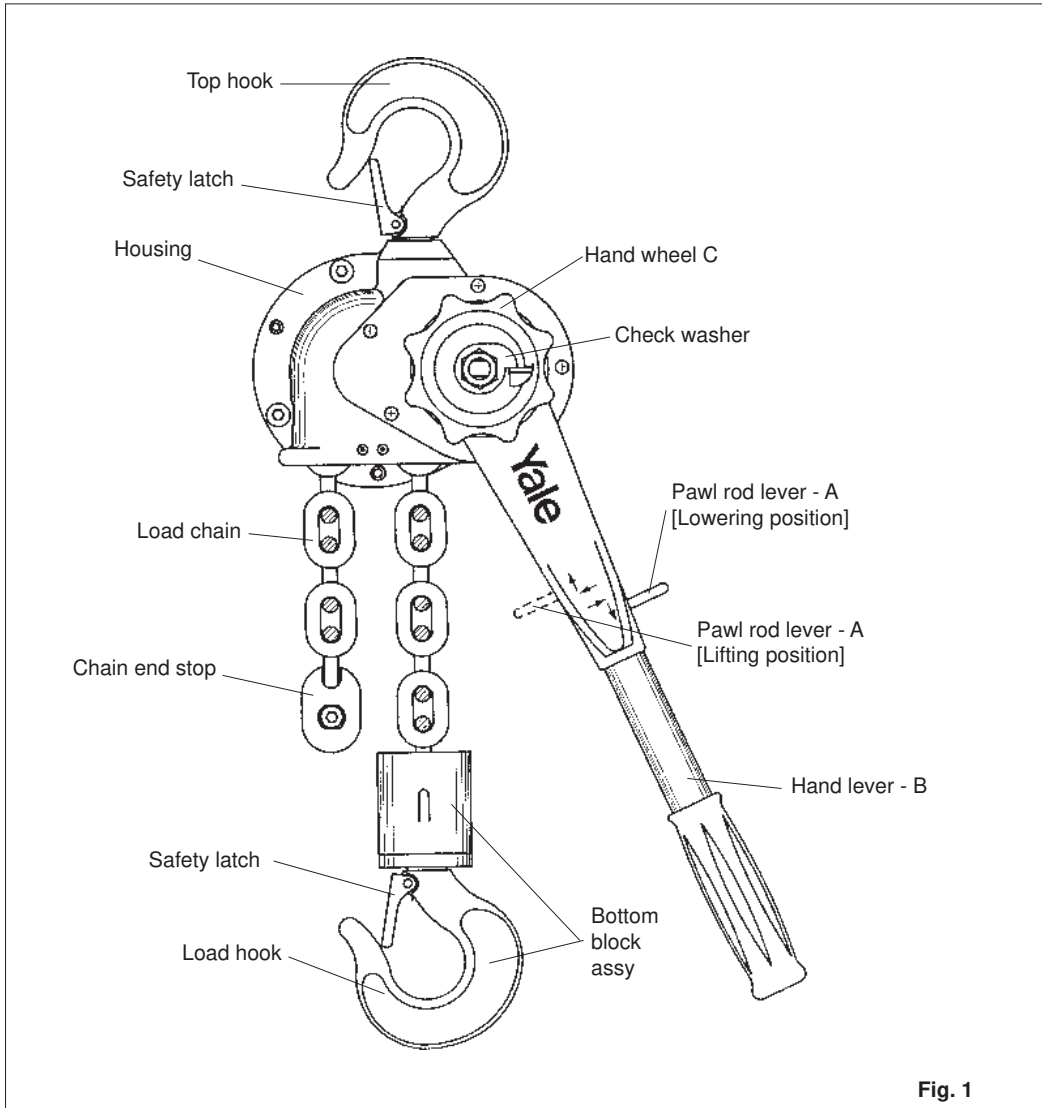

Fig. 1

Technical Information:

		Mod. D 85 with Link Chain				
Working load limit (WLL)	[kg]	750	1500	3000	6000	10000
Standard lifting height	[m]	1,5	1,5	1,5	1,5	1,5
Number of chain falls		1	1	1	2	3
Chain length	[m]	1,7	1,8	1,8	3,6	5,5
Chain dimensions d x t	[mm]	6 x 18,5	9 x 27	11 x 31	11 x 31	11 x 31
Min. headroom	[mm]	310	389	401	532	805
Hand lever length	[mm]	443	443	570	570	570
Handle pull at rated load	[daN]	38,7	31,6	40,7	42,9	35,0
Net weight at standard lift	[kg]	8,2	16,3	19,6	32,9	60,0

Technical Information:

		Mod. C 85 with Roller Chain				
Working load limit (WLL)	[kg]	750	1500	3000	6000	10000
Standard lifting height	[m]	1,5	1,5	1,5	1,5	1,5
Number of chain falls		1	1	1	2	3
Chain length	[m]	1,7	1,8	1,8	3,5	5,4
Chain dimensions d x t	[mm]	5/8"x3/8"	1"x1/2"	1 1/4"x5/8"	1 1/4"x5/8"	1 1/4"x5/8"
Min. headroom	[mm]	310	389	389	532	805
Hand lever length	[mm]	443	443	570	570	570
Handle pull at rated load	[daN]	38,7	31,6	40,7	42,9	35,0
Net weight at standard lift	[kg]	8,2	16,3	19,6	32,9	60,0

Contents:

	Page
1. Introduction	3
2. Operating Instructions	3
2.1 Correct Operations	3
• Maximum capacity	3
• Danger zones	3
• Attaching the load	3
• Temperature range	3
• Regulations	3
• Maintenance/Repair	3
2.2 Incorrect Operation:	4
2.3 Initial Operation:	4
• Inspection prior to initial operation	4
• Inspection before starting work	4
• Load chain inspection	4
• Chain stop inspection	4
• Chain alignment inspection	4
• Inspection of top and bottom hooks	4
2.4 Function / Operation:	4
• Tensioning load chain	4
• Free chaining device (if fitted)	4
• Attaching the load	5
2.5 Lifting and lowering:	5
• Lifting the load	5
• Lowering the load	5
• Brake jamming	5
• Releasing the jammed brake	5
• Yale reverse motion stop	5
• Yale overload protection device (if fitted)	5
2.6 Inspection / Maintenance:	5
• Regular inspections	5
3.0 Inspection Service and Repair:	6
• Lubrication	6
• Cleaning hooks and chains	6
• Disassemble bottom block	6
3.1 Inspect load chain:	6
• Chain alignment	6
• Installation of load chain	6
• Inspection of load chain	6
• Changing the load chain	6
3.2 Hook inspection:	7
• Inspection of top and load hook	7
• Changing top and load hook	7
3.3 Load brake inspection:	7
3.4 Final testing after service and repair:	7
3.5 Brake pawl and brake pawl spring:	7
• Brake pawl installation	7
4.0 Ordering spare parts:	7
5.0 Overload protection device (Special):	9
• Construction	9
• Assembling	9
• Function	9
6.0 Spare parts lists:	
• Mod. C/D 85 - 750 kg	10
• Mod. C/D 85 - 1500 kg	12
• Mod. C/D 85 - 3000 kg	14
• Mod. C/D 85 - 6000 kg	16
• Mod. C/D 85 - 10000 kg	18
• Slip clutch	22
• Specials	24
7.0 Inspection remarks	26
8.0 Declaration of Conformity	27

1. INTRODUCTION

All users must read these operating instructions carefully prior to the initial operation. These instructions are intended to acquaint the user with the machine/hoist and enable him to use it to the full extent of its intended capabilities.

The operating instructions contain important information on how to handle the machine/hoist in a safe, correct and economic way. Acting in accordance with these instructions helps to avoid dangers, reduce repair costs and down time and to increase the reliability and lifetime of the machine/hoist. Anyone involved in doing any of the following work with the machine/hoist must read the operation instructions and act accordingly:

- operation, including preparation, trouble shooting during operation and cleaning
- maintenance, inspection, repair
- transport

Apart from the operating instructions and the accident prevention act valid for the respective country and area where the machine/hoist is used, also the commonly accepted regulations for safe and professional work must be adhered to.

2. OPERATING INSTRUCTIONS

2.1 CORRECT OPERATION:

Maximum capacity:

- The Yale PUL-LIFT ratchet lever hoist with roller chain or link chain was designed to lift, lower and pull loads up to the working load limit. The working load limit indicated on the hoist is the maximum load that the machine is designed for and must not be exceeded.

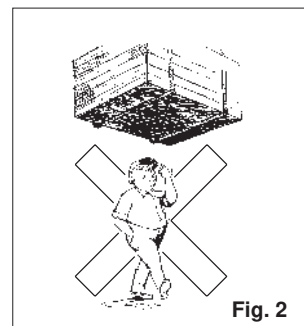

Fig. 2

Danger zones:

- Do not lift or transport loads while personnel are in the danger zone.
- Do not allow personnel to pass under a suspended load (fig 2).
- After lifting or tensioning, a load must not be left unattended.
- Start moving the load only after it has been attached correctly and all personnel are clear of the danger zone.

Attaching the load

The operator must ensure that the load is attached in a manner that does not expose himself or other personnel to danger by the hoist, chain(s) or the load.

Temperature range:

- The hoists can be operated in ambient temperatures between -10° C and +50° C.

Consult the manufacturer in case of extreme working conditions.

Note: At ambient temperatures below 0° C the brake should be checked for freezing.

Regulations

The accident prevention act and/or safety regulations of the respective country for using manual hoists must be strictly adhered to.

Maintenance / Repair:

- In order to ensure correct operation not only the operation instructions, but also the conditions for inspection and maintenance must be complied with. If defects are found stop using the hoist immediately.

2.2 INCORRECT OPERATION:

- Do not exceed the rated capacity of the hoist.
- Do not use the hoist for the transportation of people (fig. 3)
- Do not extend the hand lever (fig. 4)
- Welding on hook and load chain is strictly forbidden. The load chain must never be used as ground connection during welding (fig. 5).

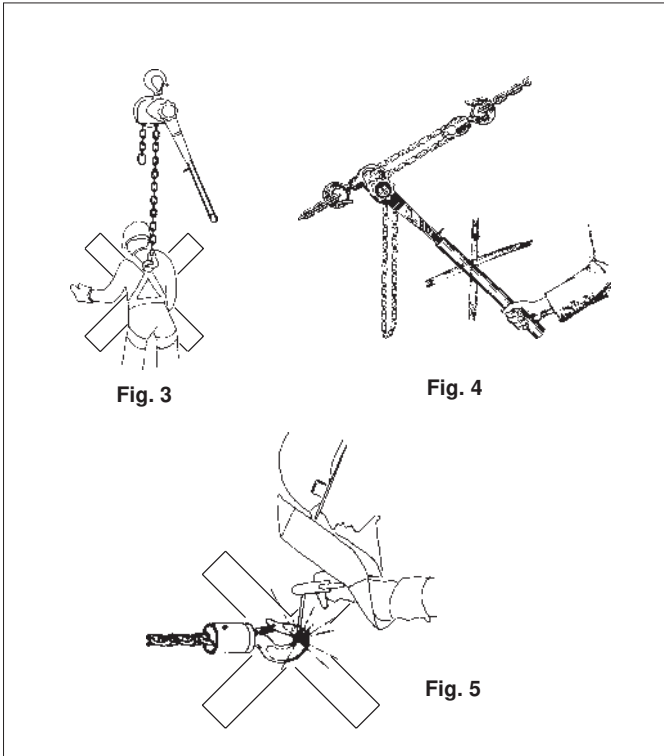

Fig. 3

Fig. 4

Fig. 5

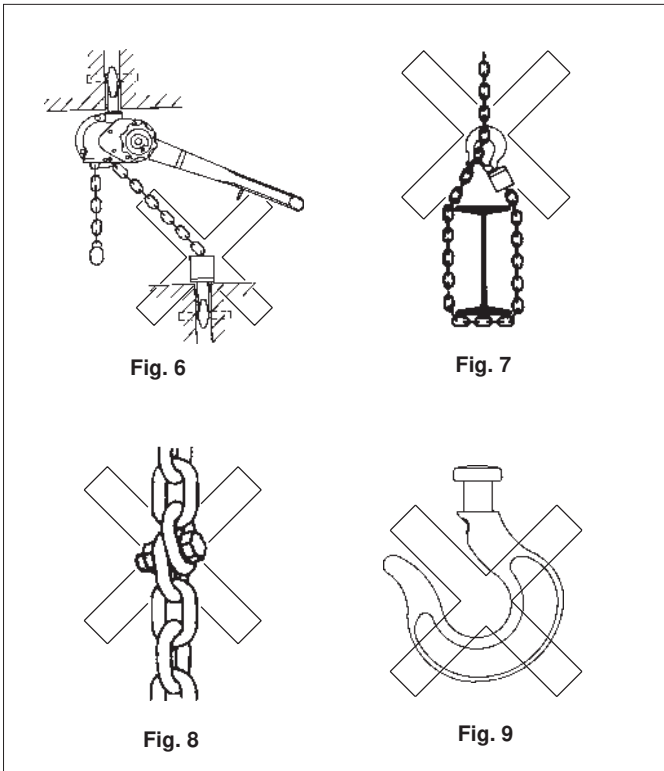

Fig. 6

Fig. 7

Fig. 8

Fig. 9

- Avoid side pull, i. e. side load on either housing or bottom block (fig.6).
- Lift/ pull/ tension only when load chain forms a straight line between both hooks.

- The load chain must not be used for lashing purposes (sling chain) (fig.7).
- Do not knot or shorten the load chain by using bolts / screws / screwdrivers or other devices (fig.8). Do not repair load chains installed in the hoist.
- Do not remove the safety latch from the top or bottom hooks.(fig.9).
- Do not use the chain stop as an operational limit device (fig.1 - chain stop)
- Do not throw the hoist down. Always place it properly on the ground.

2.3 INITIAL OPERATION:

• Inspection prior to Initial operation

Each hoist must be inspected prior to initial operation by a competent person. The inspection is visual and functional and shall establish that the hoist is safe and has not been damaged by incorrect transport or storage. Inspections should be made by a representative of the manufacturer or the supplier although the company can assign its own suitably trained personnel. Inspections are instigated by the user.

• Inspection before starting work:

Before starting work inspect the hoist, chain(s) and all load bearing constructions every time for visual defects. Furthermore test the brake and make sure that the load and hoist are correctly attached by carrying out a short work cycle of lifting/pulling or tensioning and releasing.

• Load chain inspection:

Inspect the load chain for sufficient lubrication and visually check for external defects, deformations, superficial cracks, wear or corrosion marks.

• Chain stop inspection:

The chain stop must be connected to the free (idle) chain strand. (fig.1 - chain stop).

• Chain alignment inspection:

All units equipped with two or more chain falls should be inspected prior to being put into operation for twisted or kinked chains. The chains of multiple fall hoists may be twisted if the bottom block was turned over.

• Inspection of top and bottom hooks:

Inspect top and bottom hooks for deformations, damage, cracks, wear or corrosion marks.

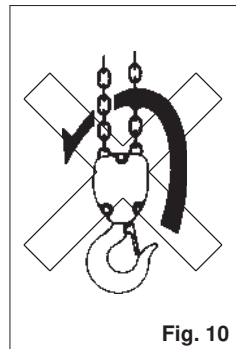

Fig. 10

2.4 FUNCTION / OPERATION

• Tensioning load chain:

Turn pawl rod lever A (fig.1) to neutral (central) position. Turn hand wheel C or pull the idle chain strand to bring the chain to the required working position and tension.

• Free chaining device (if fitted):

Turn pawl rod lever A (fig.1) to neutral (central) position. The chain can now be pulled in both directions and the bottom hook will be quickly brought to the required position.

Yale PUL-LIFT Ratchet Lever Hoist Mod. C/D85

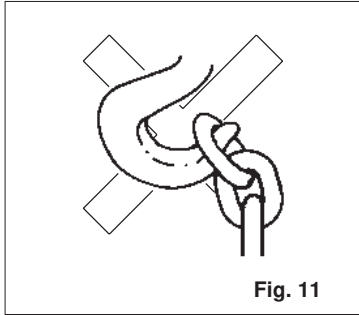

• Attaching the load:
The load must always be seated in the saddle of the hook. Never attach the load on the tip of the hook. This also applies to the top hook (fig. 11).

Fig. 11

Chain reeving models C/D 85:

The load chain has to be installed according to the illustration shown below. Hereby the welds on the standing chain links (model D 85 with link chain) must face away from the load sheave.

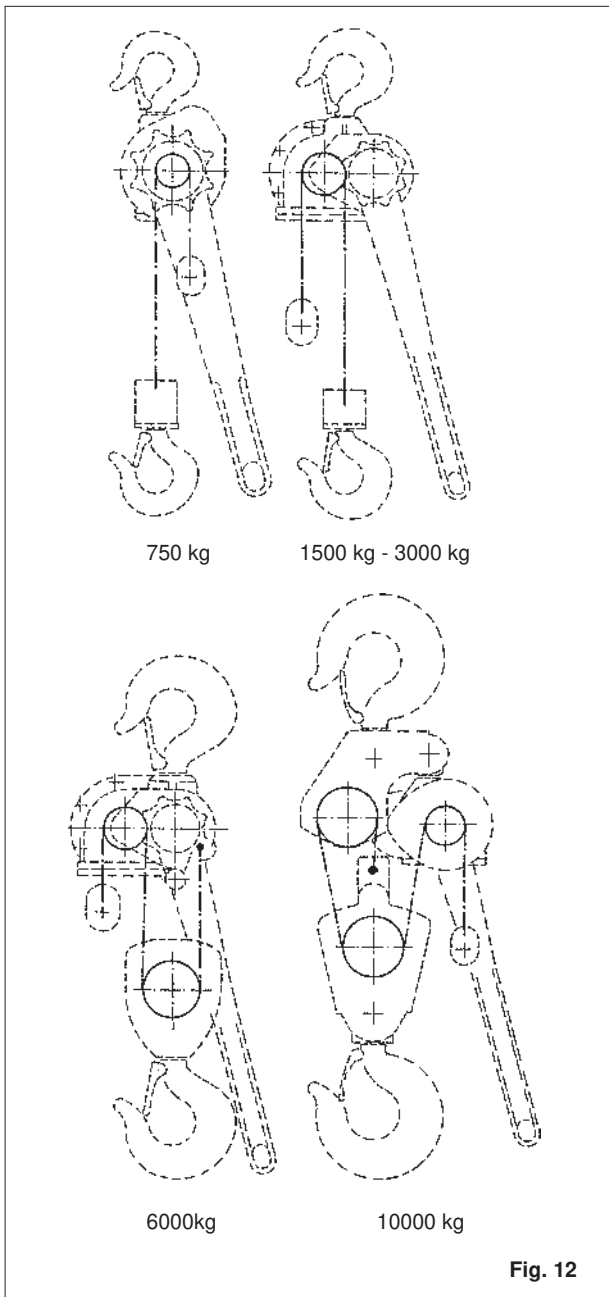

Fig. 12

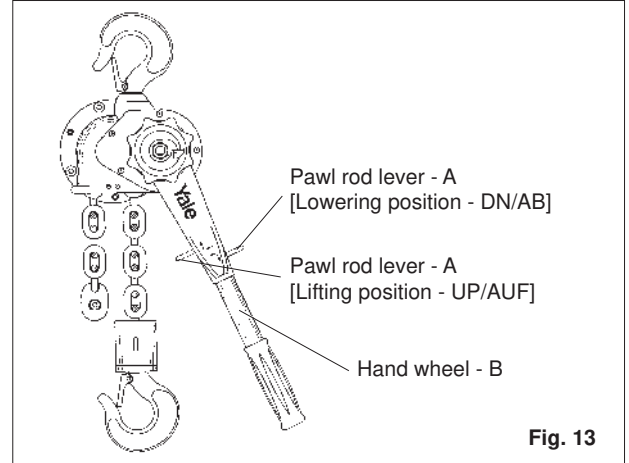

Fig. 13

2.5 LIFTING AND LOWERING:

• Lifting the load:

Turn the pawl rod lever A to the position UP/AUF. Operate the hand lever B with a pumping action. If work is stopped while the hoist is under load, the pawl rod lever A must remain in the lifting position UP/AUF. Do not switch it to neutral (centre) or lowering position DN/AB.

• Lowering of load:

Turn the pawl rod lever A to the position DN/AB. Operate hand lever B with a pumping action.

• Brake jamming

If a hoist, which is under load, is suddenly relieved of load pressure, e.g. by lifting off the load or when pulling down walls, the brake will remain locked. The brake will also lock if the bottom block is pulled too tightly against the housing.

Note: the brake is now jammed

• Releasing the jammed brake:

Turn pawl rod lever A to position DN/AB. Operate hand lever B with a vigorous stroke. If the brake is jammed on extremely tight, it can be released by striking hand lever B, ensuring pawl rod lever A is in the DN/AB position.

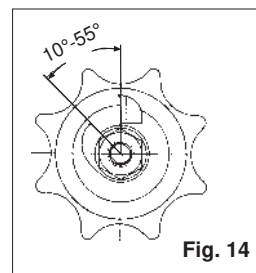

Fig. 14

• Yale reverse motion stop:

Serves to adjust brake function. **Note:** The angle between handwheel cam and check washer must be set between min. 10° and max. 55° (fig. 14).

• Yale overload protection device (if fitted):

The overload protection device is set at approx. 125% (+/- 15%)

of working load limit. For information regarding design, inspection and adjustment please refer to the relevant description (see page 9)

2.6 INSPECTION / MAINTENANCE:

• Regular inspections

To ensure that the hoists remain in safe working order they are to be subjected to regular inspections by a competent person. Inspections are to be annual unless adverse working conditions dictate shorter periods. The components of the hoist are to be inspected for damage, wear, corrosion or other irregularities and all safety devices are to be checked for completeness and effectiveness. To test the brakes and overload devices a test load of the hoist's rated capacity is required. To check for worn parts it may be necessary to disassemble the hoist. Repairs may only be carried out by a specialist workshop that uses original Yale spare parts. Inspections are instigated by the user.



Yale PUL-LIFT Ratchet Lever Hoist Mod. C/D85

3.0 INSPECTION SERVICE AND REPAIR

According to national and international accident prevention and safety regulations hoists must be inspected annually unless adverse working conditions dictate shorter periods. The initial and recurring inspections are to be documented in the enclosed Yale inspection certificate or on page 26.

Repairs may only be carried out by specialist workshops that use original Yale spare parts.

Recommendation: Replace friction discs and pawl springs during the annual service.

• LUBRICATION

To reduce wear on the load chain, spray it now and again with chain oil. Also pack the disassembled gearbox with Shell FD2 or equivalent grease.

Attention: Keep friction discs absolutely free from oil, grease, water or dirt.

• CLEANING HOOKS AND CHAINS

Flame-cleaning is forbidden. Use only cleansing methods and agents that do not corrode the chain material. Avoid cleansing methods that can lead to hydrogen brittleness e.g. spraying or dipping chain in caustic solvents. Also avoid surface treatments that can hide crack and flaws or other surface damage

• Disassemble bottom block

Grip the load hook in a vice. With a flat drift bend back the tabs that secure the swivel tube. Tap off the swivel tube in the direction of the chain. The swivel halves, hook and chain can now be separated.

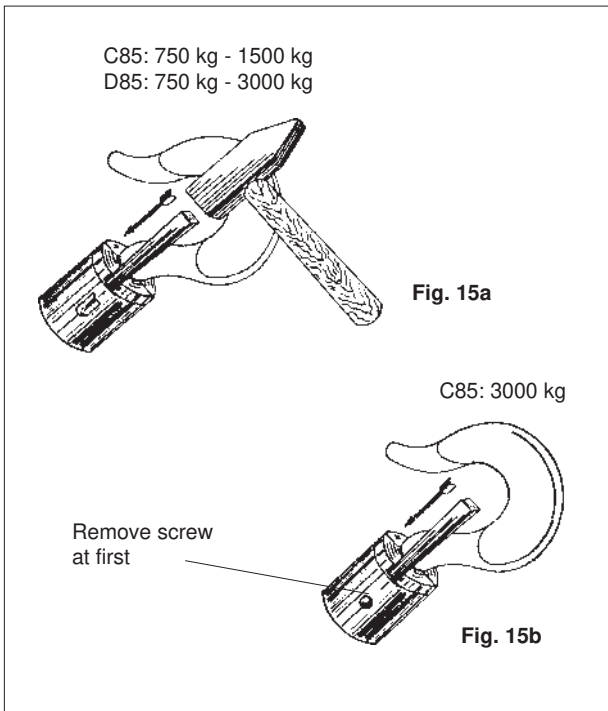

3.1 Inspect load chain

• Chain alignment

The welds on the standing links must face away from the sheave

• Installation of load chain

Instigated by the user, all load chains in service must be inspected annually unless adverse working conditions dictate shorter periods. Visually inspect the chain for deformation, cracks, flaws, elongation wear or corrosive pitting. Chains that do not fulfil all requirements must be replaced immediately.

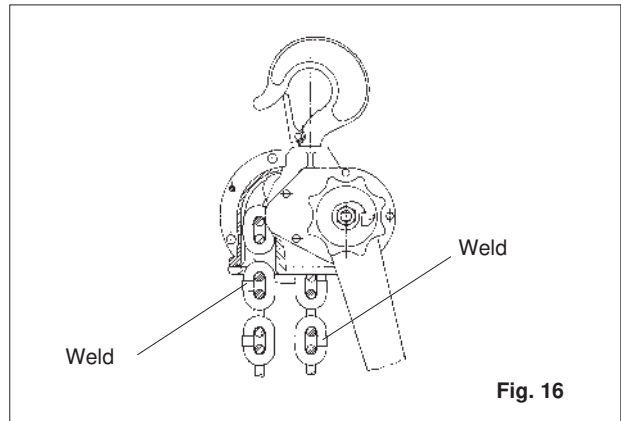

• Changing The Load Chain

Link chains must be replaced when the nominal thickness "d" on any part of the chain has been reduced by more than 10% (measuring see fig. 17a) or when the pitch "t" is elongated by more than 5% or over 11 partitions (11 x t) by 3%. Nominal dimension and wear limits are shown in following table.

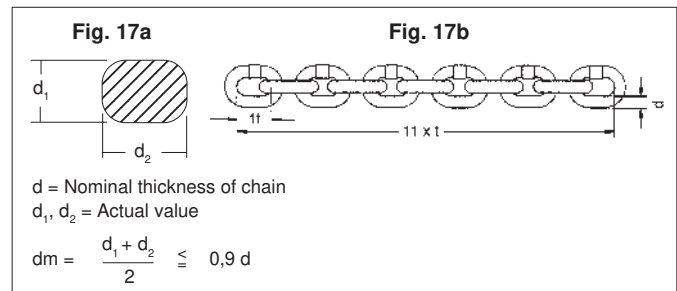

	750 kg D85	1500 kg D85	3000 kg D85	6000 kg D85	10000 kg D85
Link Chain	6 x 18,5	9 x 27	11 x 31	11 x 31	11 x 31
Nom. thckn. d nom. mm	6	9	11	11	11
Nom. thckn. d min. mm	5,4	8,1	9,9	9,9	9,9
Pitch t nom. mm	18,5	27	31	31	31
Pitch t max. mm	19,5	28,5	32,8	32,8	32,8
Meas. lgth. 11 t nom. mm	203,5	297	341	341	341
Meas. lgth. 11 t max. mm	210,1	306,9	351,7	351,7	351,7

Yale PUL-LIFT Ratchet Lever Hoist Mod. C/D85



• Changing The Load Chain

Roller chains must be replaced when the whole chain or one link is elongated by more than 3% or when the whole chain or part of it has been pulled stiff. Furthermore roller chains may not be used if the rollers are deformed or broken or the outer contour of the plates are damaged or worn. Nominal dimension and wear limits are shown in following table.

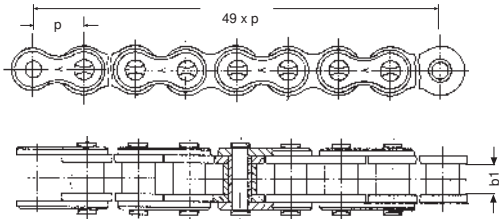

		750 kg C85	1500 kg C85	3000 kg C85	6000 kg C85	10000 kg C85
Roller Chain		5/8" x 3/8"	1" x 1/2"	1 1/4" x 5/8"	1 1/4" x 5/8"	1 1/4" x 5/8"
Pitch	p nom. mm	15,875	25,4	31,75	31,75	31,75
Pitch	p max. mm (+ 3 %)	16,35	26,16	32,7	32,7	32,7
Inner width	b ₁ nom. mm	9,53	12,7	16	16	16
Meas. lgth.	49 p nom. mm	777,9	1244,6	1555,8	1555,8	1555,8
Meas. lgth.	49 p max. mm (+ 3 %)	801,2	1281,9	1602,4	1602,4	1602,4

3.2 Hook inspection

• Inspection of Top- and Load Hook

Inspect the load hook for deformation, damage, surface cracks, wear and corrosion as required but at annually unless adverse working conditions dictate shorter periods. Hooks that do not fulfil all requirements must be replaced immediately.

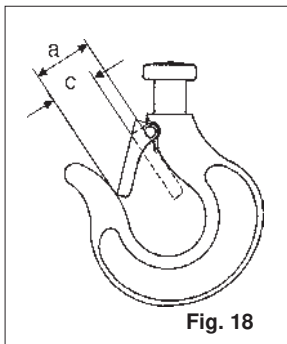

• Changing top and load hook

Load hooks must be replaced when the mouth of the hook has opened by more than 10% or the nominal value of other dimensions decrease by 5% due to wear (see fig 18). Nominal dimension and wear limits are shown in following table.

		750 kg C/D85	1500 kg C/D85	3000 kg C/D85	6000 kg C/D85	10000 kg C/D85
Hook						
c	mm	23,0	25,0	34,0	46,0	52,0
a	nom. mm	28,6	33,3	39,5	50,0	64,0
a	max. mm	31,4	36,6	43,5	55	70,4
Hook			(from June 94)			
c	mm		30,0			
a	nom. mm		30,0			
a	max. mm		33,0			

3.3 Inspect The Load Brake

Inspect the condition and effectiveness of the brake.

The friction discs must be free from oil, grease, water and dirt at all times. We recommend replacing the friction discs during the annual service.

Adverse working conditions can make shorter inspection periods necessary. Before initial operation and before starting work, inspect the hoist, accessories and all load bearing constructions for obvious faults and defects.

Furthermore test the brake and make sure that the load and hoist are correctly attached by carrying out a short work cycle of lifting/pulling or tensioning and releasing.

3.4 Final Testing After Service Or Repair

After service or repair every hoist must be final tested with a load at least as heavy as the working load limit of that particular hoist .

(max. value = 1,25 x working load limit)

3.5 Pawls and pawl springs.

To replace pawls and pawl springs proceed as follows (see Fig. 19, next page).

4.0 Ordering Spare Parts

When ordering spare parts, always quote the part.-no., description and the quantity. If in doubt please also quote model, rated load capacity, serial-no. and year of construction so that positive identification can be made.

We cannot guarantee for repairs or the replacement of parts that we do not carry out ourselves.

Yale PUL-LIFT Ratchet Lever Hoist Mod. C/D85

Fig. 19

Installation of the Brake pawl

Mod. C/D85 - 750 kg

up to 11/92 with 1 Brake pawl spring

alternative installation into older housings until 1992

either

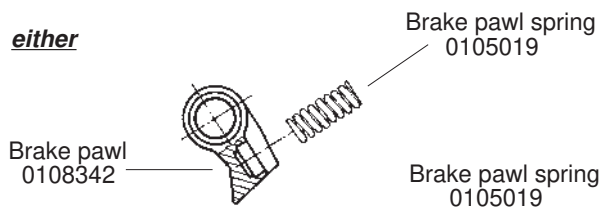

or

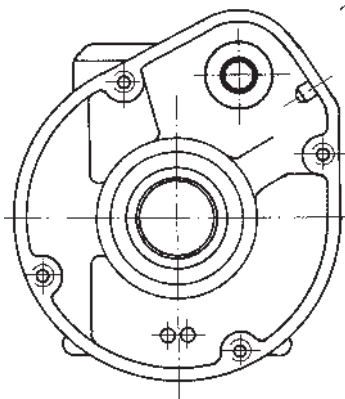
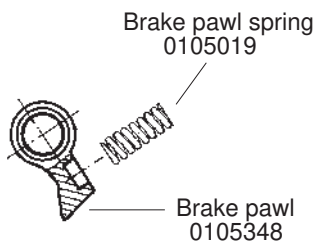

3/4 t C/D Housing
Part No. 0106207

from 11/92 with 2 Brake pawl spring

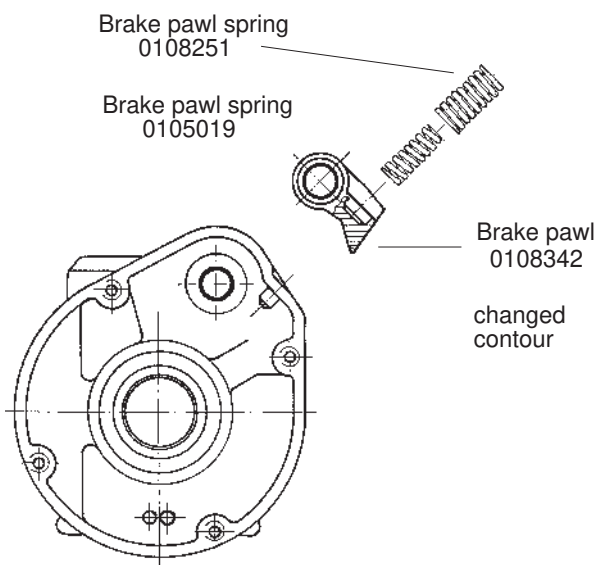

3/4 t C/D Housing, Part No. 0106207
with changes in the area of the brake pawl pin

Mod. C/D85 - 1500 - 10000 kg

ut to 11/92 with 1 Brake pawl spring

Brake pawl spring
0105019

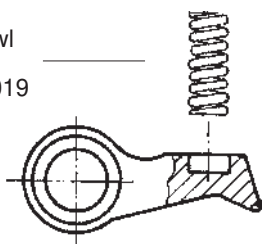

Brake pawl :
1,5 t C/D 85 = 0105346
3, 6 u. 10 t C/D 85 = 0105336

from 11/92 with 2 Brake pawl spring

Installation of the new brake pawl without changes of the housing

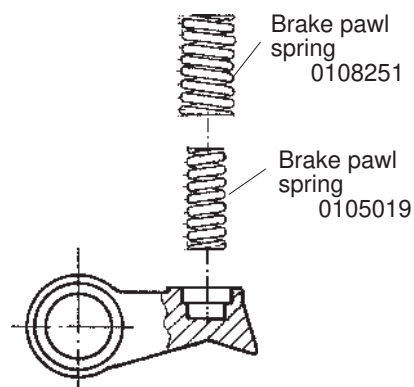

Brake pawl :
1,5 t C/D 85 = 0108287
3, 6 u. 10 t C/D 85 = 0108289

Yale PUL-LIFT Ratchet Lever Hoist Mod. C/D85



5.0 Overload protection device (Special).

• Construction

The overload protection device is an adjustable slip clutch which is fitted in an enlarged hand lever head. The necessary parts for the installation of the slip clutch you will find on page 22.

• Assembling

Items 2 to 7 are assembled to a complete unit. Depending on hoist model each clutch is tightened with a torque wrench to a prescribed value. The torque values (see settings at the ratchet disc, item 4) are shown in the table below. The self-locking slotted nut (7) maintains the adjustment. The clutch assembly can now be screwed onto the extended drive pinion (1).

Fit the hand lever (13) and secure with handwheel (9), check washer (11), tooth washer (Z) and nut (N). A spring loaded release mechanism (17) is fitted into the hand lever.

• Function

The directions lifting (AUF) and lowering (AB) are shown on the hand lever and are engaged by turning the pawl rod lever to the desired position. When the max. overload limit is reached, the ratchet disc (4) slips between the two friction discs (3) so preventing dangerous overloading of the hoist. The reverse motion stop (mechanical brake) is always effective even when the overload clutch slips. By repositioning the pawl rod lever (19) the load can be lowered in the normal manner. If the hand lever also slips in the lowering direction, the release mechanism must be activated by depressing the release pin (17) while operating the hand lever in the lowering direction. The depressed release pin engages in the disc hub and makes a mechanical connection. The release pin is spring loaded and disengages automatically when released. If, during inspection, the overload limit is found to be incorrect due to wear, the clutch can be readjusted by retightening with a torque wrench.

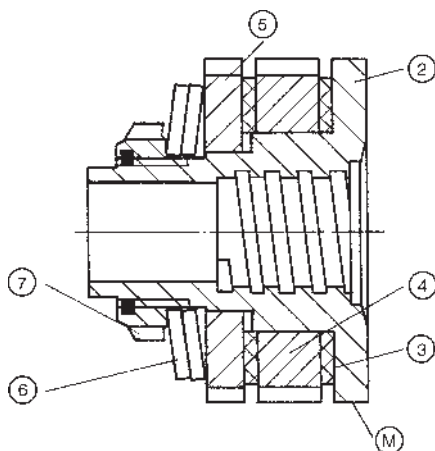
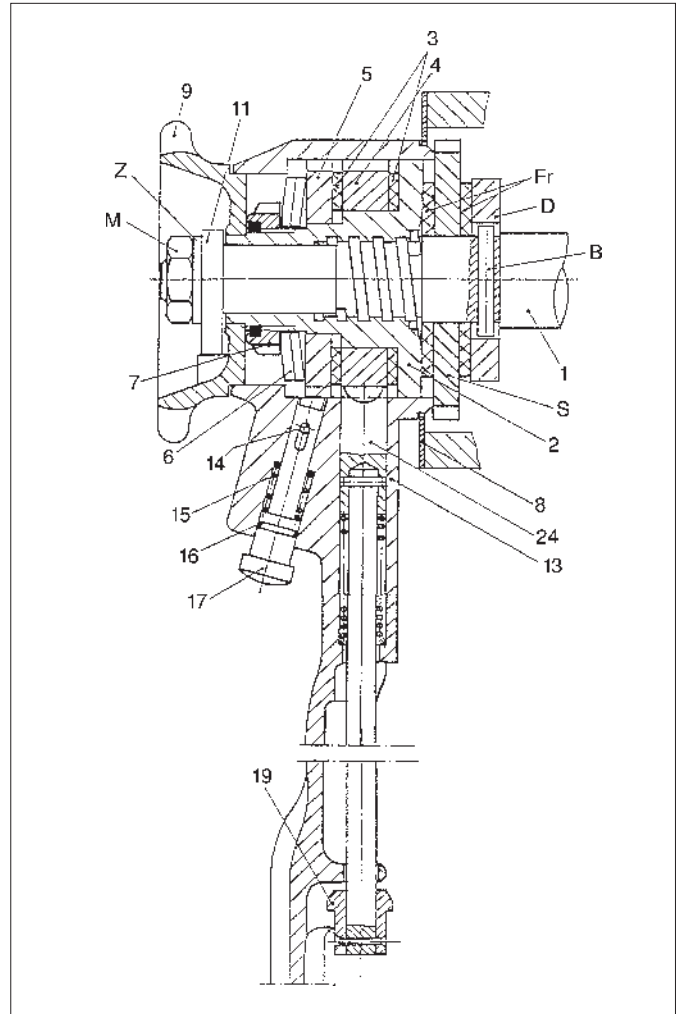

Marked with a character

Character	Type Mod. C	Typ Mod.D85 Mod.C85	Settings at the Ratchet disc (4) (Nm)	Part No.
A	0,75 t	0,75 t	185 - 205	0105844
B		1,5 t	150 - 168	0105845
C	4,5 t	3,0 t	270 - 292	0105846
D	6,0 t	6,0 t	280 - 313	0105847
E	1,5 t/2-str.		205 - 223	0107492
G	1,5 t/1-str.		220 - 240	0105884
H	3,0 t		251 - 274	0107493

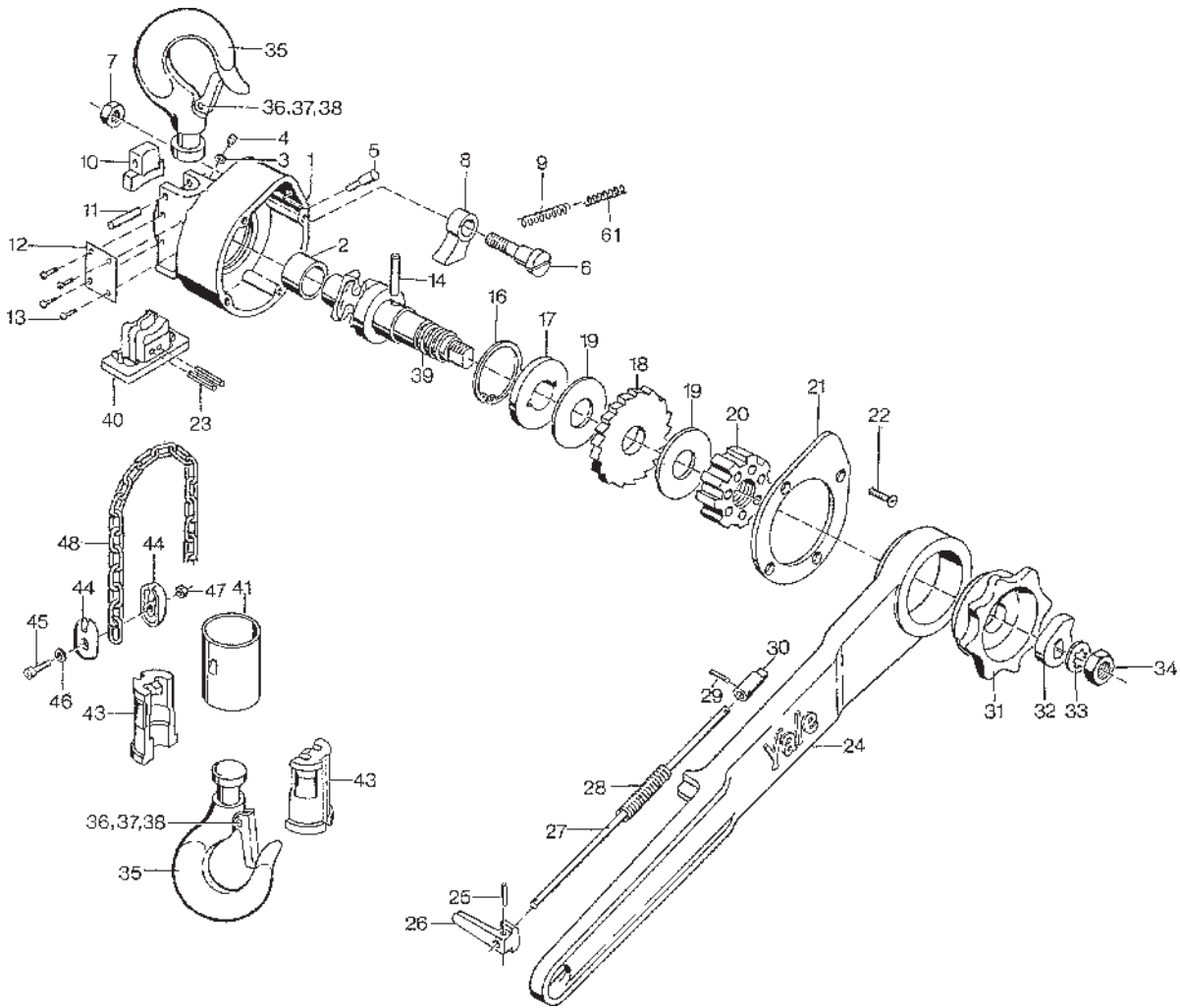

Parts for Model C 85 with Roller Chain

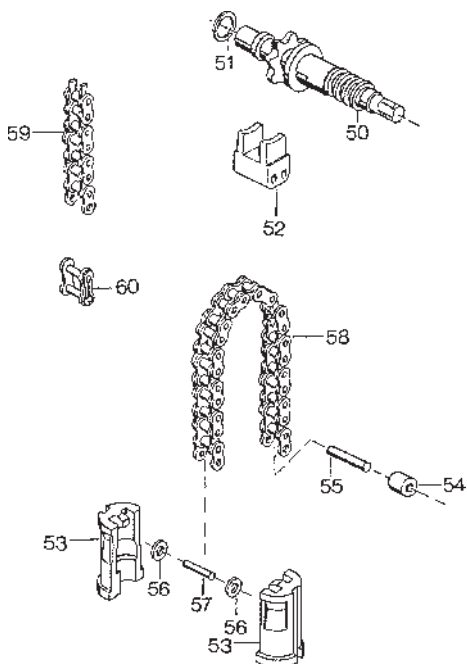

Parts for rubber grip lever (cpl.= No. 68)

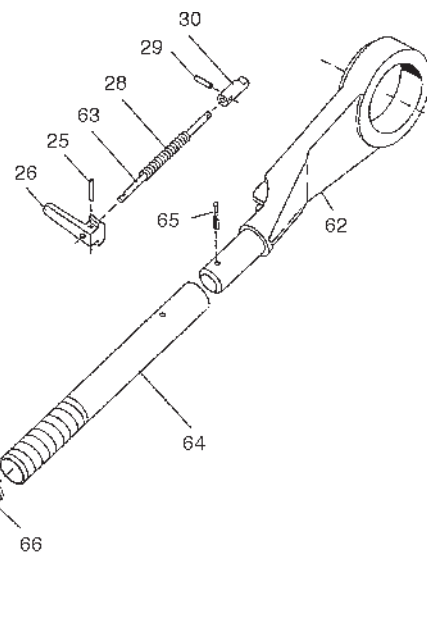



Item No.	Part No.	Description	No. off
Common parts for both models			
1-5	0106207	Housing assy	1
2	0102503	Bushing	1
3	0104986	Washer	1
4	9176014	Lub fitting	1
5	0105020	Brake pawl spring pin	1
6	0111108	Brake pawl bolt	1
7	9115147	Hex. nut	1
8 *	0108342	Brake pawl	1
9 *	0105019	Brake pawl spring	1
10	0111106	Fitting piece	1
11	9134018	Locking sleeve	1
12	0107487	Name plate	1
13	9128008	Grooved nail	4
14	0106254	Bolt	1
16	9130022	Retaining ring	1
17	0103895	Disc hub	1
18	0105075	Ratchet disc	1
19	0108500	Friction disc, asbestos-free	2
20	0101028	Ratchet	1
21	0111029	Load brake cover	1
22	9104116	Screw	4
23	9134050	Locking sleeve	2
24-30	0105969	Hand lever assy	1
24	0105939	Hand lever, 443 mm	1
25	0102136	Lever rod p	1
26	0102135	Pawl rod lever	1
27	0102131	Ratchet rod	1
28	0102132	Lever pawl spring	1
29	0102134	Ratchet rod pin	1
30	0102133	Ratchet pawl	1
31	0102037	Hand wheel	1
32	0102038	Check washer	1
33	9123018	Tooth washer	1
34	9115059	Hex. nut	1
35-38	0000858	Hook assy	2
36-38	0106370	Safety latch kit	2
41	0108241	Swivel tube	1
61 *	0108251	Brake pawl spring	1
62	0107660	Lever head	1
63	0107666	Ratched rod	1
64	0107730	Tube	1
65	9134094	Locking sleeve	1
66	0108351	Plug	1
67	0246418	Grip	1
68	0108787	Rubber grip lever, cpl.	1
Parts for Model C85 with Roller Chain only			
35-38, 41 + 53	0100283	Bottom block assy	1
50	0105698	Sprocket wheel	1
51	9121205	Washer	1
52	0105916	Stripper	1
53	0100276	Swivel half	2
54-55	0106232	Chain stop assy	1
54	0105913	Chain stop	1
55	0108448	Chain bolt	1
56	0105589	Chain washer	2
57	0108448	Chain bolt	1
54-58	1205955	Load chain, length 1,68 m	1
59	1244800	Load chain, (specify length)	1
60	0109474	Chain lock	1
Parts for Model D85 with link chain only			
35-38 +41-43	0100305	Bottom block assy	1
39	0103144	Load sheave	1
40	0105942	Stripper	1
43	0104979	Swivel half	2
44-47	0104639	Chain stop assy	1
44	0104630	Chain stop half	2
45	9102169	Cyl. screw	1
46	9122031	Lockwasher	1
47	9115002	Hex. nut	1
48	1607633	Load chain zinc coat. (specify length)	1

* Installation see page 8

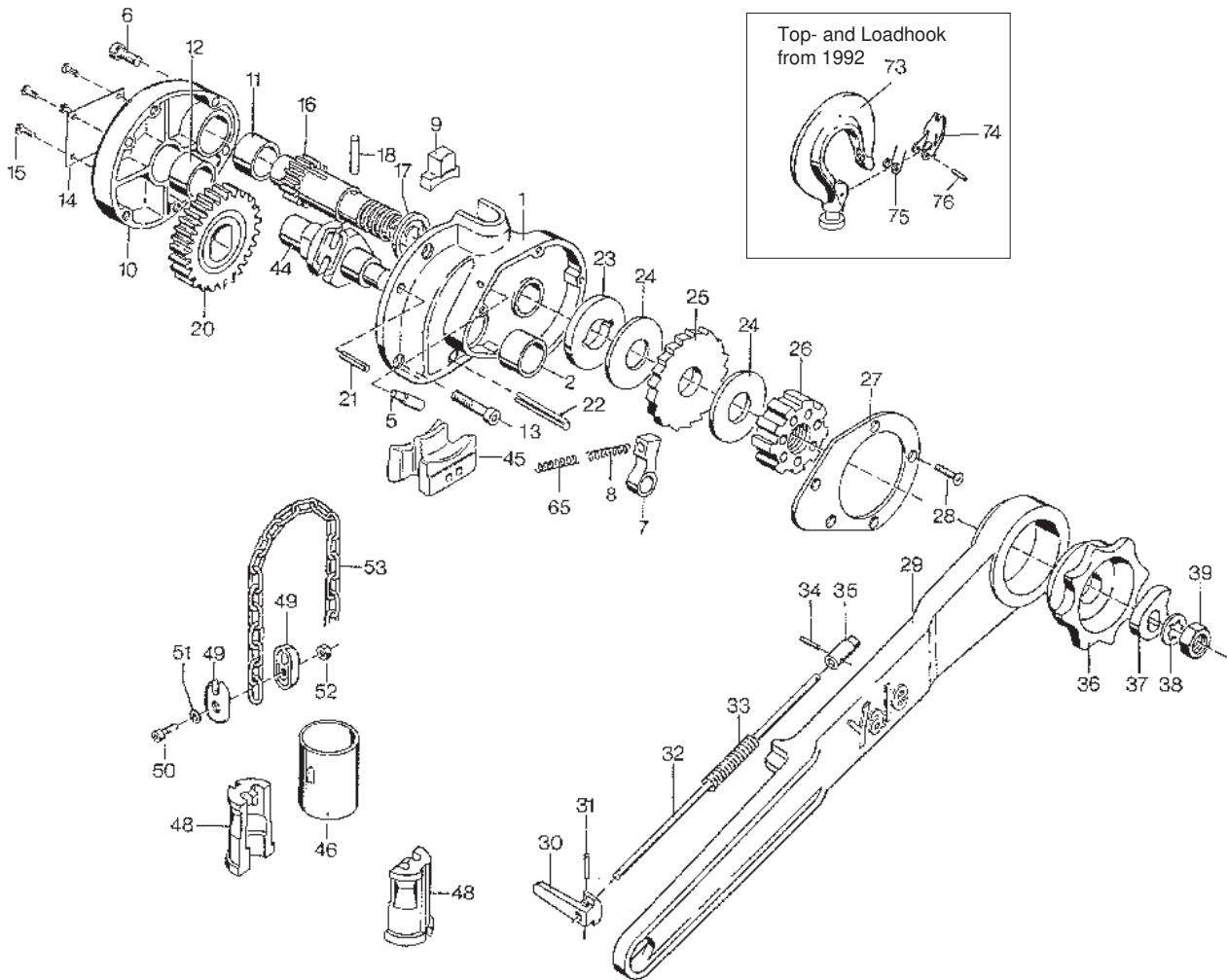

Parts for Model C 85 with roller chain

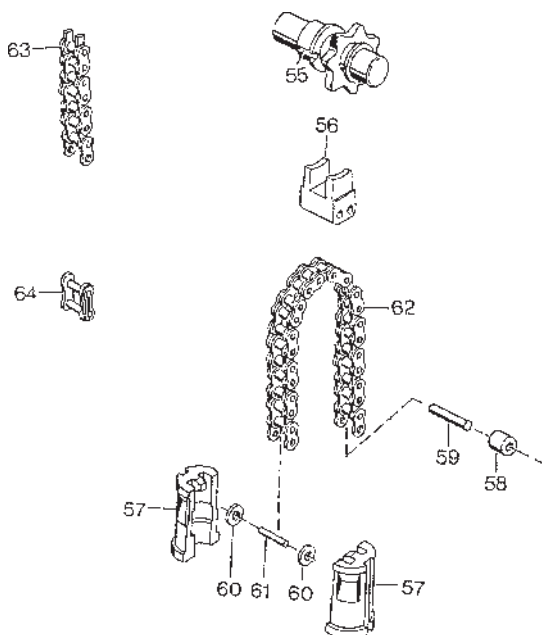

Parts for rubber grip lever (cpl.= No. 72)

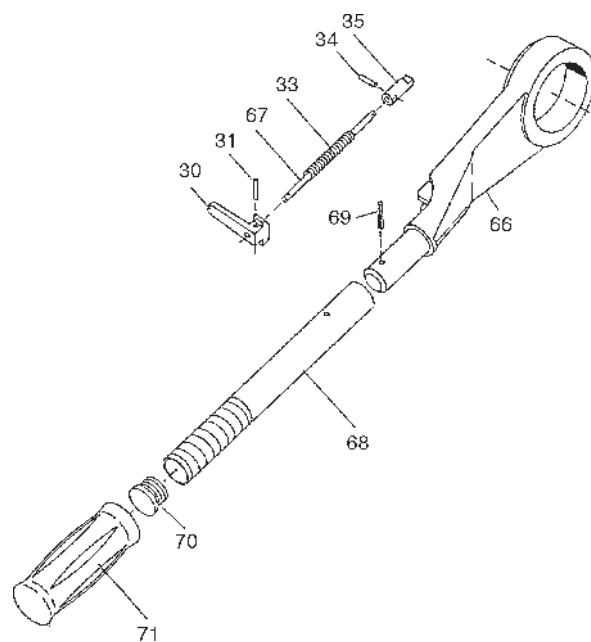

Yale PUL-LIFT Ratchet Lever Hoist Mod. C/D85 1500 kg



Item No..	Part No.	Description	No. off
Common parts for both models			
1-2+5-6	0106208	Housing assy	1
2	0105930	Bushing	1
5	0105020	Brake pawl spring pin	1
6	9105005	Cyl. screw	2
7 *	0108287	Brake pawl	1
8 *	0105019	Brake pawl spring	1
9	0103205	Fitting piece	1
10-13	0106209	Housing cover assy	1
11	0102503	Bushing	1
12	0105930	Bushing	1
13	9105010	Cyl. screw	2
14	0107487	Name plate	1
15	9128008	Grooved nail	4
16	0103146	Drive pinion	1
17	0111017	Spacer	1
18	0106254	Bolt	1
20	0103806	Gear	1
21	9134028	Locking sleeve	2
22	9134003	Locking sleeve	2
23	0103895	Disc hub	1
24	0108500	Friction disc, asbestos-free	2
25	0105075	Ratchet disc	1
26	0101028	Ratchet	1
27	0106001	Load brake cover	1
28	9104116	Screw	5
29-35	0105969	Hand lever assy	1
29	0105939	Hand lever, 443 mm	1
30	0102135	Pawl rod lever	1
31	0102136	Lever rod pin	1
32	0102131	Ratchet rod	1
33	0102132	Lever pawl spring	1
34	0102134	Ratchet rod pin	1
35	0102133	Ratchet pawl	1
36	0102037	Hand wheel	1
37	0102038	Check washer	1
38	9123018	Tooth washer	1
39	9115059	Hex. nut	1
40-43	0100916	Hook assy	2
41-43	0106371	Safety latch kit	2
46	0106048	Swivel tube	1
65 *	0108251	Brake pawl spring	1
66	0107660	Lever head	1
67	0107666	Ratchet rod	1
68	0107730	Tube	1
69	9134094	Locking sleeve	1
70	0108351	Plug	1
71	0246418	Grip	1
72	0108787	Rubber grip lever, cpl.	1
73-76	0108247	Hook, cpl. (from1992)	2
74-76	0109081	Safety latch kit	2
Parts for Model C85 with Roller Chain only			
40-43,46, 57	0100365	Bottom block assy	1
55	0105900	Sprocket wheel	1
56	0105917	Stripper	1
57	0100382	Swivel half	2
58-59	0106233	Chain stop assy	1
58	0105914	Chain stop	1
59	0105986	Chain bolt	1
60	0105588	Chain washer	2
61	0105986	Chain bolt	1
63	1245700	Load chain, (specify length)	
58-62	1205956	Load chain, length 1,73 m	1
64	0106079	Chain lock	1
Parts for Model D85 with link chain only			
40-43 +46-48	0100311	Bottom block assy	1
44	0103805	Load sheave	1
45	0105697	Stripper	1
48	0100173	Swivel half	2
49-52	0104640	Chain stop assy	1
49	0104631	Chain stop half	2
50	9102103	Cyl. screw	1
51	9122032	Lockwasher	1
52	9115014	Hex. nut	1
53	1607645	Load chain zinc coat. (specify length)	

* Installation see page 8

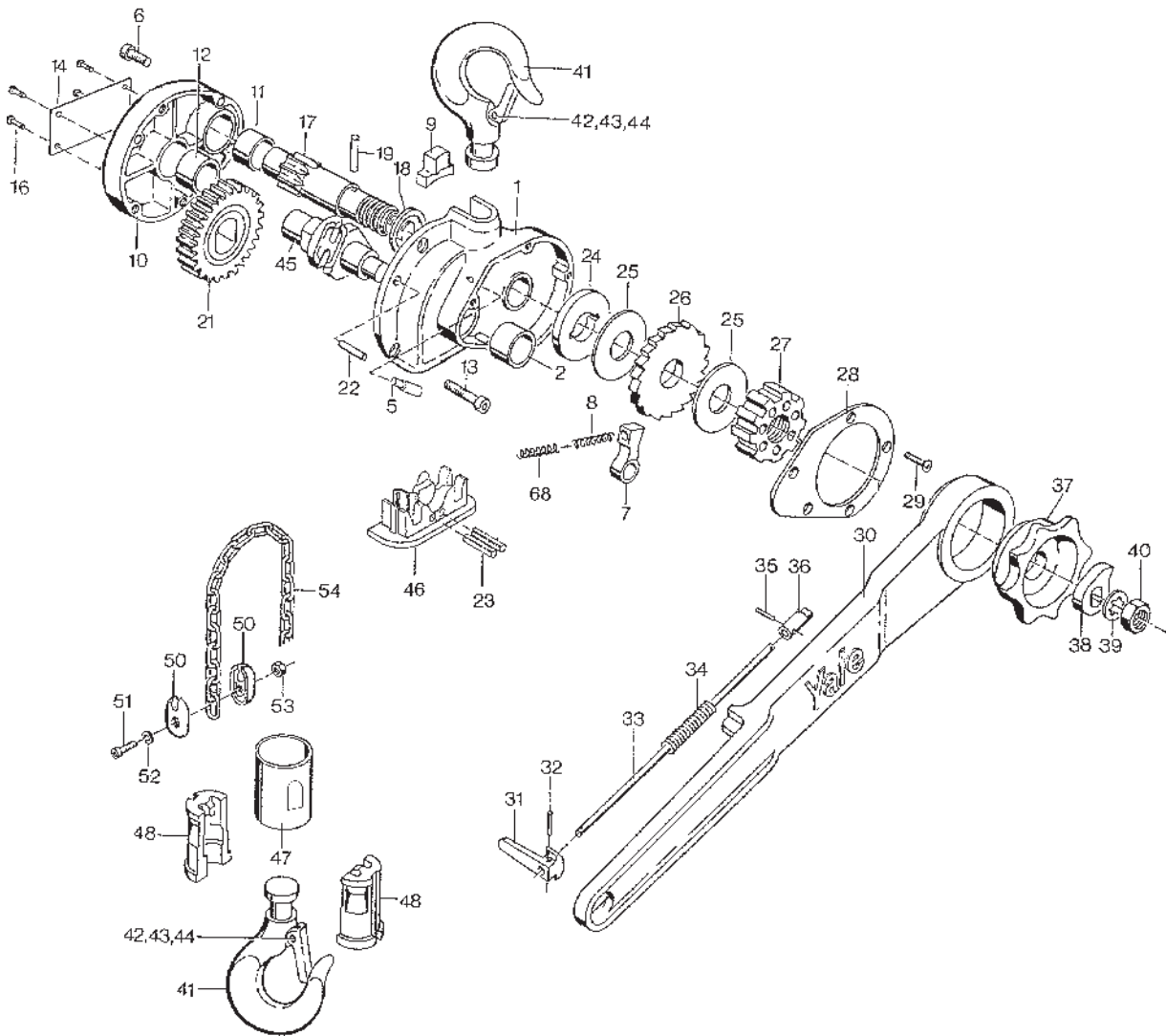

Parts for Model C 85 with roller chain

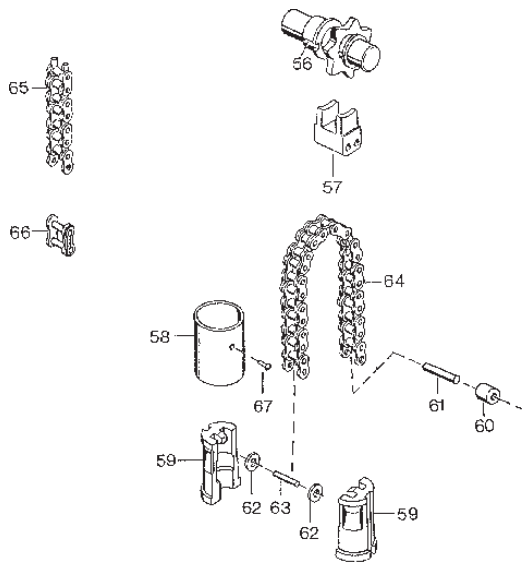

Parts for rubber grip lever (cpl.= No. 75)

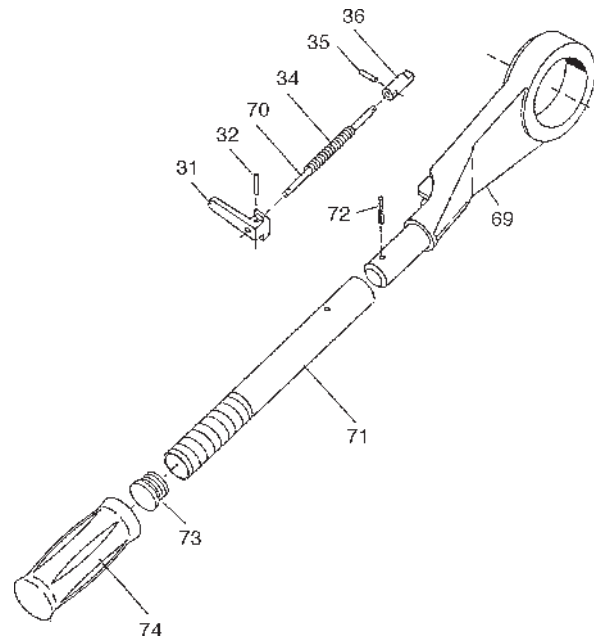

Yale PUL-LIFT Ratchet Lever Hoist Mod. C/D85 3000 kg



Item No.	Part No.	Description	No. off
Common parts for both models			
1-2, 5-6	0106219	Housing assy	1
2	0105929	Bushing	1
5	0105020	Brake pawl spring pin	1
6	9105006	Cyl. screw	2
7 *	0108289	Brake pawl	1
8 *	0105019	Brake pawl spring	1
9	0104951	Fitting piece	1
10-13	0106220	Housing cover assy	1
11	0106248	Bushing	1
12	0105929	Bushing	1
13	9105011	Cyl. screw	2
14	0107487	Name plate	1
16	9128008	Grooved nail	4
17	0106096	Drive pinion	1
18	0105989	Spacer	1
19	0106254	Bolt	1
21	0103808	Gear	1
22	9134001	Locking sleeve	2
23	9134097	Locking sleeve	2
24	0103895	Disc hub	1
25	0108500	Friction disc, asbestos-free	2
26	0105075	Ratchet disc	1
27	0101028	Ratchet	1
28	0106002	Load brake cover	1
29	9104116	Screw	5
30-36	0106221	Hand lever assy	1
30	0105940	Hand lever, 570 mm	1
31	0102135	Pawl rod lever	1
32	0102136	Lever rod pin	1
33	0102131	Ratchet rod	1
34	0102132	Lever pawl spring	1
35	0102134	Ratchet rod pin	1
36	0102133	Ratchet pawl	1
37	0102037	Hand wheel	1
38	0102038	Check washer	1
39	9123018	Tooth washer	1
40	9115059	Hex. nut	1
41-44	0101072	Hook assy	2
42-44	0106372	Safety latch kit	2
68 *	0108251	Brake pawl spring	1
69	0107660	Lever head	1
70	0107666	Ratchet rod	1
71	0107731	Tube	1
72	9134094	Locking sleeve	1
73	0108351	Plug	1
74	0246418	Grip	1
75	0108788	Rubber grip lever, cpl.	1
Parts for Model C85 with Roller Chain only			
41-44, +58,59,67	0106224	Bottom block assy	1
56	0105903	Sprocket wheel	1
57	0105920	Stripper	1
58+67	0106223	Swivel tube with taptite screw	1
59	0105573	Swivel half	2
60-61	0106234	Chain stop assy	1
60-64	1205957	Load chain, length 1,78 m	1
60	0105915	Chain stop	1
61	0105567	Chain bolt	1
62	0105582	Chain washer	2
63	0105567	Chain bolt	1
65	1245701	Load chain, (specify length)	1
66	0106235	Chain lock	1
67	9106343	Screw	2
Parts for Model D85 with link chain only			
41-44 +47, 48	0109100	Bottom block assy	1
45	0103807	Load sheave	1
46	0105695	Stripper	1
47 **	0108132	Swivel tube	1
48 **	0108134	Swivel half	2
50-53	0104641	Chain stop assy	1
50	0104632	Chain stop half	2
51	9102092	Cyl. screw	1
52	9122032	Lockwasher	1
53	9115014	Hex. nut	1
54	1607652	Load chain zinc coat. (specify length)	1

* Installation see page 8

** Only use completely

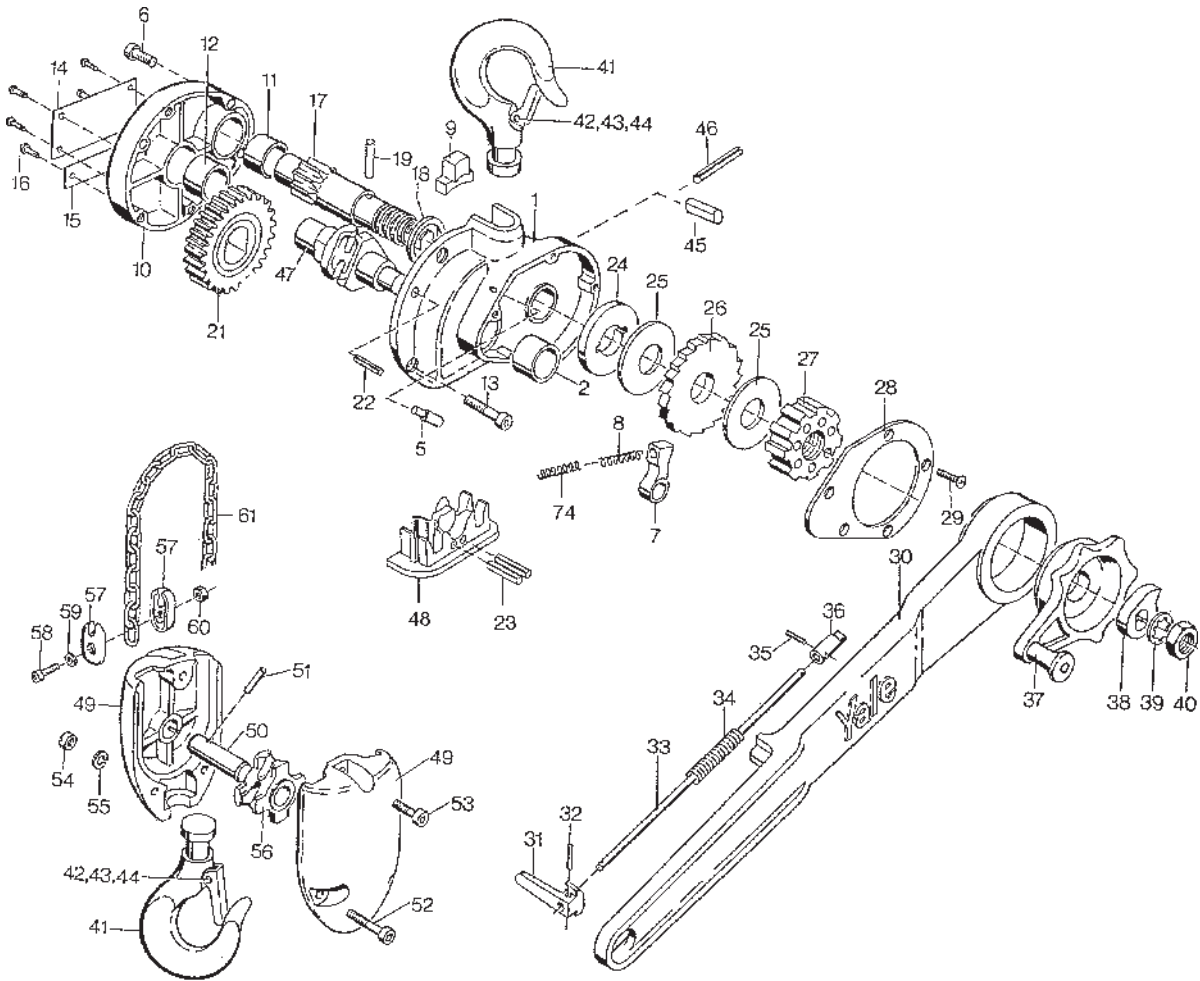

Parts for Model C 85 with roller chain

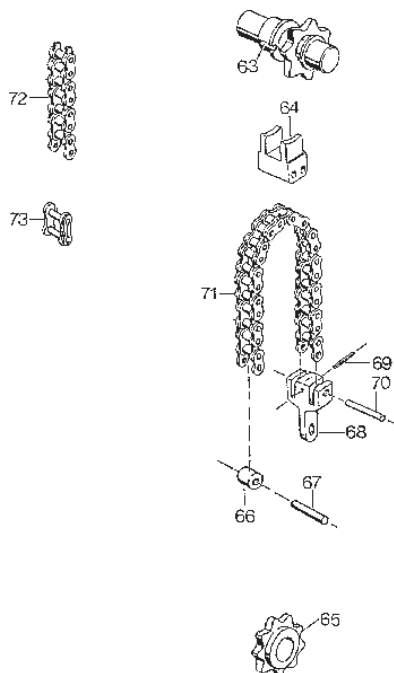

Parts for rubber grip lever (cpl.= No. 81)

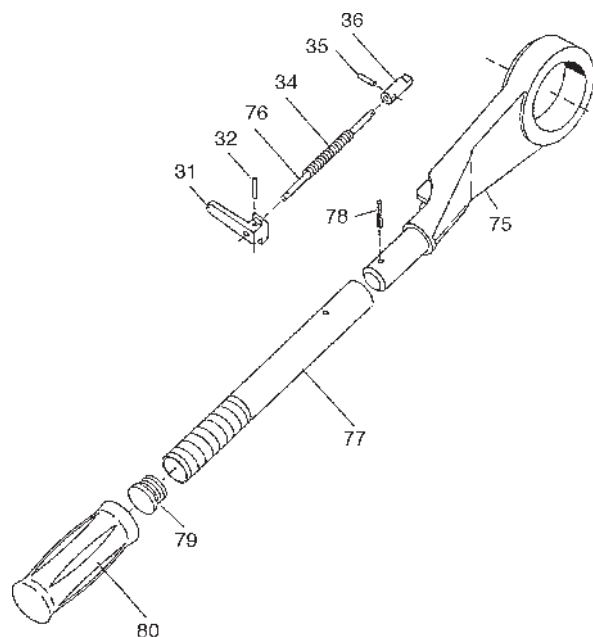

Yale PUL-LIFT Ratchet Lever Hoist Mod. C/D85 6000 kg



Item No.	Part No.	Description	No. off
Common parts for both models			
1-2, 5-6	0106225	Housing assy	1
2	0105929	Bushing	1
5	0105020	Brake pawl spring pin	1
6	9105006	Cyl. screw	2
7 *	0108289	Brake pawl	1
8 *	0105019	Brake pawl spring	1
9	0103207	Fitting piece	1
10-13, +15	0104954	Housing cover assy	1
11	0106248	Bushing	1
12	0105929	Bushing	1
13	9105011	Cyl. screw	2
14	0107487	Name plate	1
15	0105599	Capacity plate	1
16	9128008	Grooved nail	6
17	0106096	Drive pinion	1
18	0105989	Spacer	1
19	0106254	Bolt	1
21	0103808	Gear	1
22	9134001	Locking sleeve	2
23	9134097	Locking sleeve	2
24	0103895	Disc hub	1
25	0108500	Friction disc, asbestos-free	2
26	0105075	Ratchet disc	1
27	0101028	Ratchet	1
28	0106002	Load brake cover	1
29	9104116	Screw	5
30-36	0106221	Hand lever assy	1
30	0105940	Hand lever, 570 mm	1
31	0102135	Pawl rod lever	1
32	0102136	Lever rod pin	1
33	0102131	Ratchet rod	1
34	0102132	Lever pawl spring	1
35	0102134	Ratchet rod pin	1
36	0102133	Ratchet pawl	1
37	0102091	Crank hand wheel assy	1
38	0102038	Check washer	1
39	9123018	Tooth washer	1
40	9115059	Hex. nut	1
41-44	0104944	Hook assy	2
42-44	0106373	Safety latch kit	2
45	0105964	Chain bolt	1
46	9134110	Locking sleeve	1
49	0105945	Swivel half	2
50	0103131	Idler sheave shaft	1
51	9134055	Locking sleeve	1
52	9102010	Cyl. screw	2
53	9102029	Cyl. screw	1
54	9118020	Slotted nut	3
55	9122032	Lockwasher	3
74 *	0108251	Brake pawl spring	1
75	0107660	Lever head	1
76	0107666	Ratchet rod	1
77	0107731	Tube	1
78	9134094	Locking sleeve	1
79	0108351	Plug	1
80	0246418	Grip	1
81	0108788	Rubber grip lever, cpl.	1
Parts for Model C85 with Roller Chain only			
41-44, +49-55,65	0106227	Bottom block assy	1
63	0105903	Sprocket wheel	1
64	0105920	Stripper	1
65	0105919	Idler sprocket	1
66-67	0106234	Chain stop assy	1
66	0105915	Chain stop	1
67	0105567	Chain bolt	1
68	0105928	Chain anchor	1
69	9134046	Locking sleeve	1
70	0105931	Chain bolt	1
72	1245701	Load chain, (specify length)	1
66-67, 71	1205958	Load chain, length 3,52 m	1
73	0106235	Chain lock	1
Parts for Model D85 with link chain only			
41-44 +49-56	0106247	Bottom block assy	1
47	0103807	Load sheave	1
48	0105695	Stripper	1
56	0118244	Idler sheave	1
57-60	0104641	Chain stop assy	1
57	0104632	Chain stop half	2
58	9102092	Cyl. screw	1
59	9122032	Lockwasher	1
60	9115014	Hex. nut	1
61	1607652	Load chain zinc coat. (specify length)	1

* Installation see page 8

Yale PUL-LIFT Ratchet Lever Hoist Mod. C/D85 10000 kg

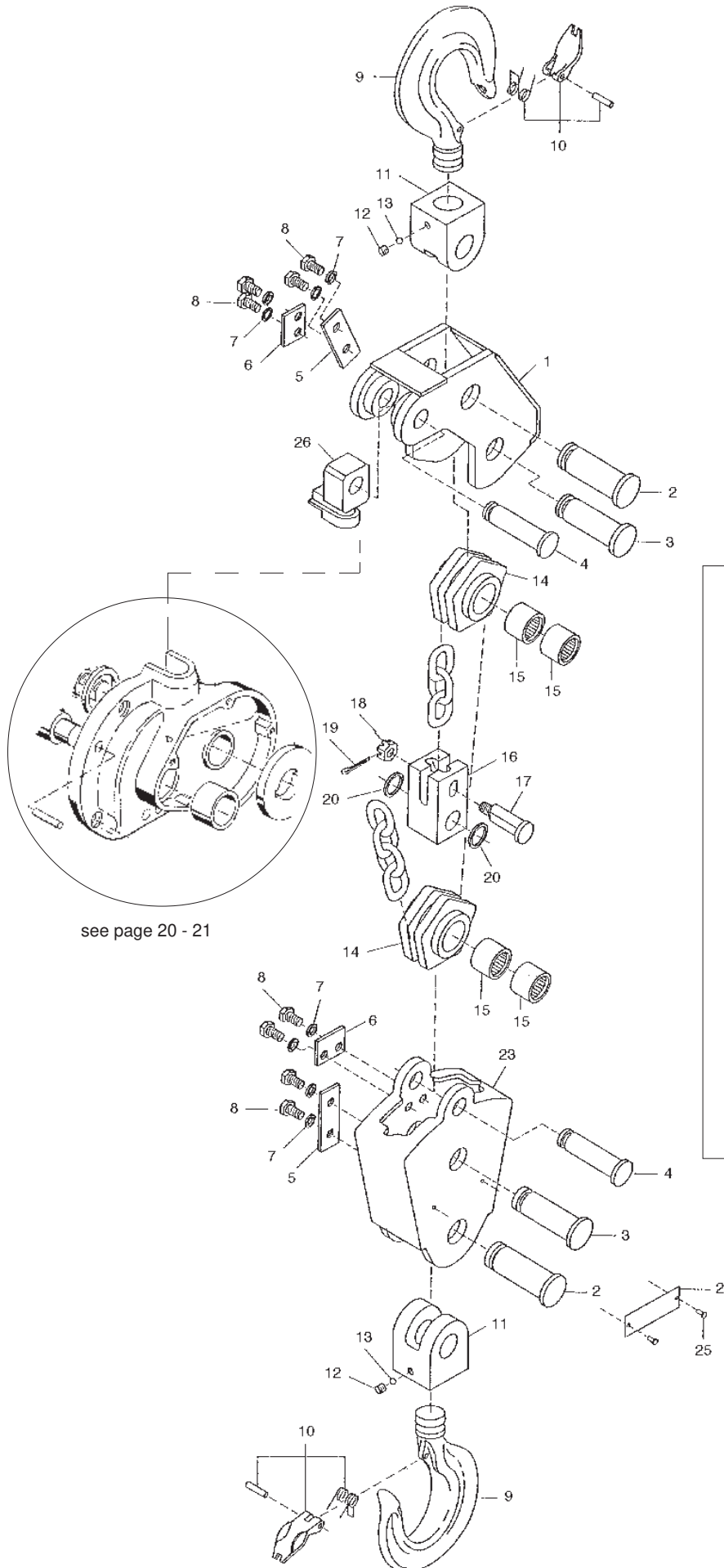

see page 20 - 21

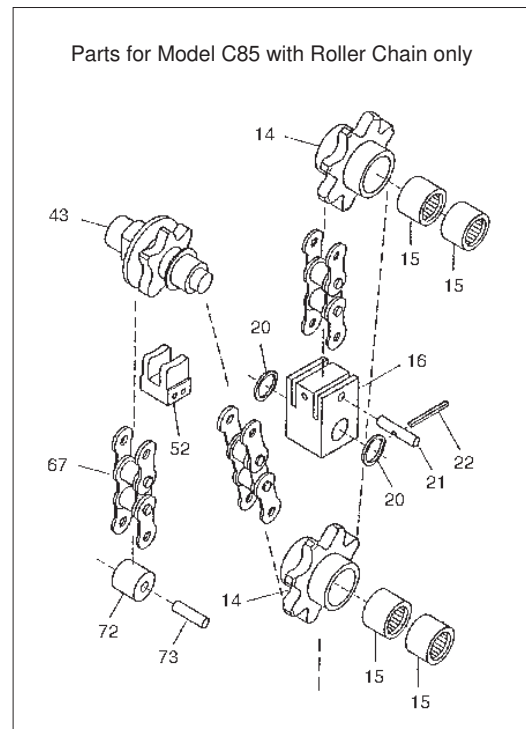

Yale PUL-LIFT Ratchet Lever Hoist Mod. C/D85 10000 kg



Item No.	Part No.	Description	No. off
Common parts for both models			
1-8	0109024	Crosshead assy	1
1	0108585	Crosshead	1
2	0407687	Idler sheave shaft	2
3	0108586	Idler sheave shaft	2
4	0108300	Supporting bolt	2
5	0108303	Axle support	2
6	0108304	Axle support	2
7	9122005	Lockwasher	8
8	9101016	Screw	8
9-10	0408488	Hook assy	2
10	0408769	Safety latch kit	2
11-12	0407792	Crosshead assy	2
12	0407794	Threaded pin	2
13	0407790	Ball set	2
15	9153020	Needle bearing	4
20	0717046	Washer	2
23-25, 2-8	0109025	Coupling frame, cpl.	1
23	0108299	Coupling frame	1
24	0407702	Capacity plate	1
25	9128004	Grooved nail	8
26	0107187	Eye bolt	1
Parts for Model C85 with Roller Chain only			
14	0107272	Idler sheave	2
16	0108302	Chain anchor	1
21	0105931	Chain bolt	1
22	9134117	Locking sleeve	1
43	0105903	Sprocket wheel	1
52	0105920	Stripper	1
67	1245701	Load chain, (specify length)	1
72-73	0106234	Chain stop assy	1
72	0105915	Chain stop	1
73	0105567	Chain bolt	1
Parts for Model D85 with link chain only			
14	0108149	Idler sheave	2
16	0108301	Chain anchor	1
17	0108151	Hinge bolt	1
18	0306056	Castel nut	1
19	9125045	Cotter pin	1

Yale PUL-LIFT Ratchet Lever Hoist Mod. C/D85 10000 kg

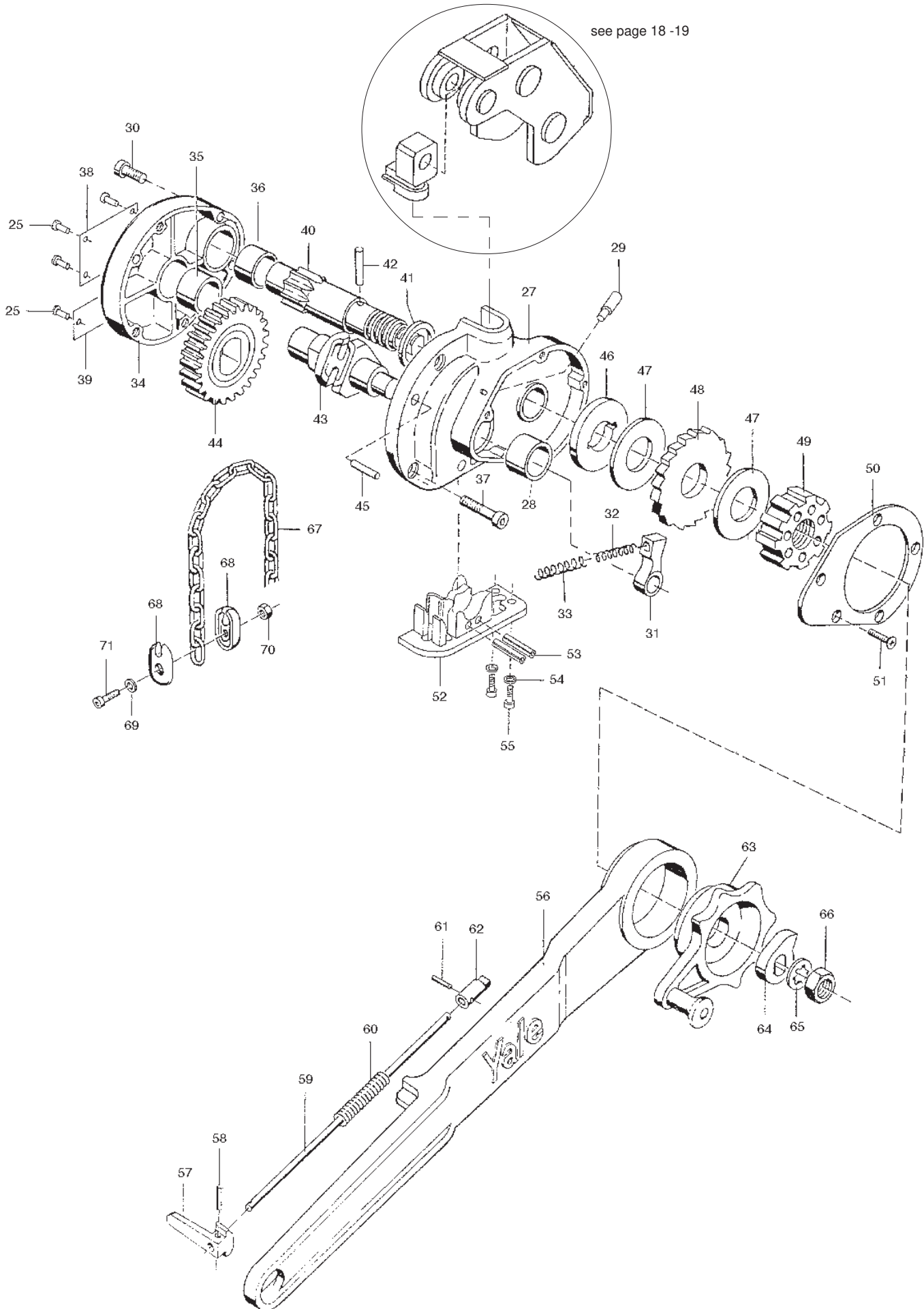

Yale PUL-LIFT Ratchet Lever Hoist Mod. C/D85 10000 kg



Item No.	Part No.	Description	No. off
Common parts for both models			
25	9128004	Grooved nail	8
28	0107524	Bushing	1
29	0105020	Brake pawl spring pin	1
30	9105006	Cyl. screw	2
31 *	0108289	Brake pawl	1
32 *	0105019	Brake pawl spring	1
33 *	0108251	Brake pawl spring	1
34-37	0109028	Housing cover assy	1
34	0105690	Housing cover	1
35	0107524	Bushing	1
36	0106248	Bushing	1
37	9105011	Cyl. screw	2
38	0106255	Name plate	1
39	0107189	Capacity plate	1
40	0106096	Drive pinion	1
41	0105989	Spacer	1
42	0106254	Bolt	1
44	0157460	Gear	1
45	9134001	Locking sleeve	2
46	0103895	Disc hub	1
47	0108500	Friction disc, asbestos-free	2
48	0105075	Ratchet disc	1
49	0101028	Ratchet	1
50	0106002	Load brake cover	1
51	9104116	Screw	5
53	9134097	Locking sleeve	2
56-62	0106221	Hand lever assy	1
56	0105940	Hand lever	1
57	0102135	Pawl rod lever	1
58	0102136	Lever rod pin	1
59	0102131	Ratchet rod	1
60	0102132	Lever pawl spring	1
61	0102134	Ratchet rod pin	1
62	0102133	Ratchet pawl	1
63	0102091	Crank hand wheel assy	1
64	0102038	Check washer	1
65	9123018	Tooth washer	1
66	9115059	Hex. nut	1
Parts for Model C85 with Roller Chain only			
27-30	0109027	Housing assy	1
27	0107279	Housing	1
Parts for Model D85 with link chain only			
27-30	0109026	Housing assy	1
27	0108156	Housing	1
43	0103807	Load sheave	1
52	0108150	Stripper	1
54	9122031	Lockwasher	2
55	9102248	Cyl. screw	2
67	1607652	Load chain zinc coat. (specify length)	1
68-71	0104641	Chain stop assy	1
68	0104632	Chain stop half	2
69	9122032	Lockwasher	1
70	9115014	Hex. nut	1
71	9102092	Cyl. screw	1

* Installation see page 8



Yale PUL-LIFT Ratchet Lever Hoist Mod. C/D85 Slip Clutch

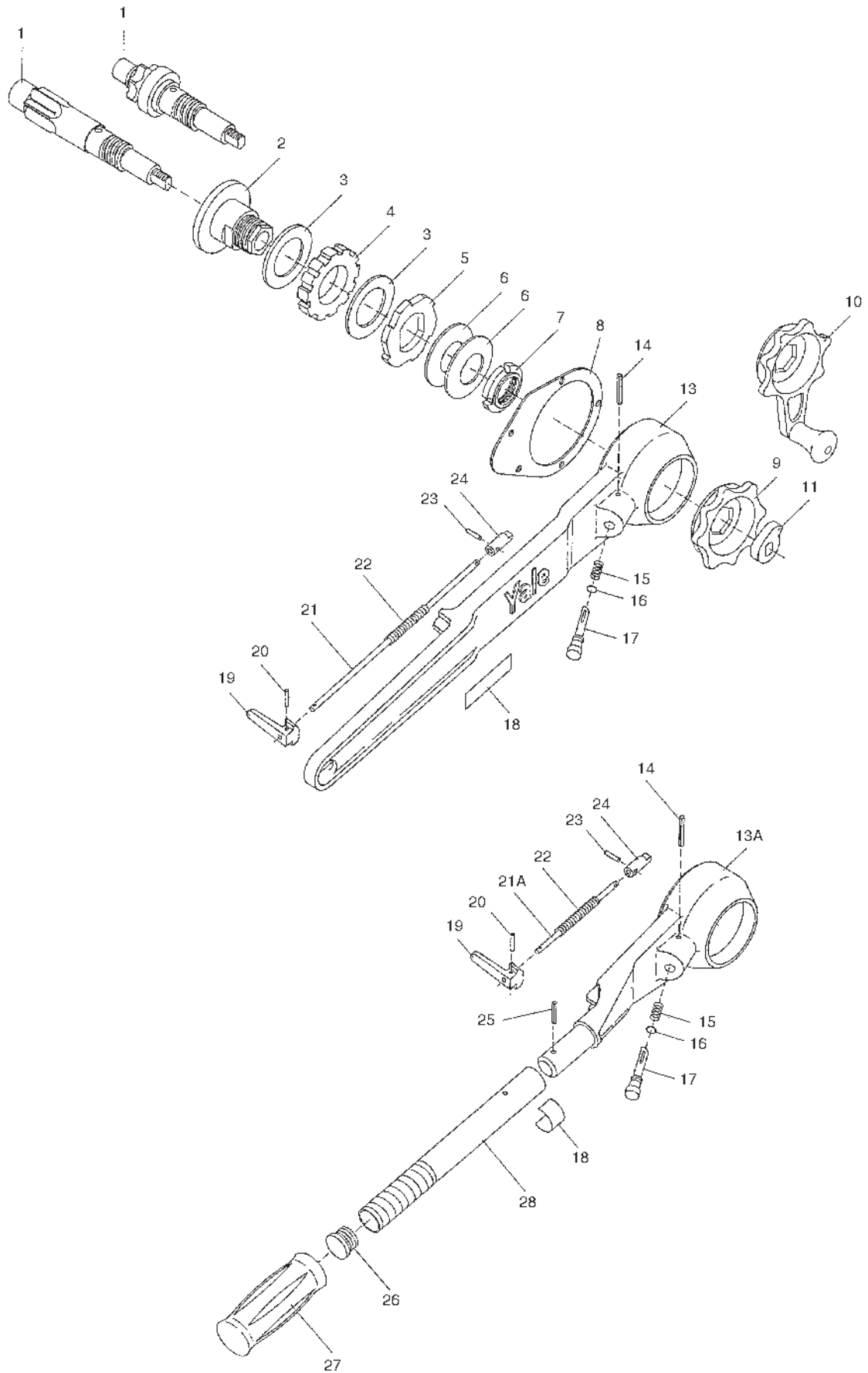

Yale PUL-LIFT Ratchet Lever Hoist Mod. C/D85 Slip Clutch



Item No.	Part No.	Description	No. off
Common parts for all capacities			
2	0105837	Hub	1
3	0105840	Friction disc, asbestos-free	2
4	0105838	Ratchet	1
5	0105839	Disc hub	1
6	9120044	Cup spring	2
7	0107244	Nut	1
11	0105853	Check washer	1
13A	0107661	Lever head, cpl.	1
14	9134033	Locking sleeve	1
15	0105852	Spring	1
16	9171160	O-Ring	1
17	0105851	Release pin	1
18	0107448	Tag	1
19	0102135	Pawl rod lever	1
20	0102136	Lever rod pin	1
21	0102131	Ratchet rod (for No 13)	1
21A	0107666	Ratchet rod (for No 13A)	1
22	0102132	Lever pawl spring	1
23	0102134	Ratchet rod pin	1
24	0102133	Ratchet pawl	1
25	9134094	Locking sleeve	1
26	0108351	Plug	1
27	0246418	Grip	1
Parts for Capacity 750 kg only			
1	0107240	Sprocket wheel C85	1
	0107241	Sprocket wheel D85	1
2-7	0105844	Slip clutch, cpl.	1
8	0107242	Load brake cover	1
9	0105848	Hand wheel	1
13-24	0107491	Lever, cpl. (malleable iron)	1
13A-28	0108064	Lever, cpl. (rubber grip)	1
13	0107490	Lever (malleable iron)	1
28	0107730	Tube	1
Parts for Capacity 1500 kg only			
1	0105880	Drive pinion	1
2-7	0105845	Slip clutch, cpl.	1
8	0105881	Load brake cover	1
9	0105848	Hand wheel	1
13-24	0107491	Lever, cpl. (malleable iron)	1
13A-28	0108064	Lever, cpl. (rubber grip)	1
13	0107490	Lever (malleable iron)	1
28	0107730	Tube	1
Parts for Capacity 3000 kg only			
1	0105850	Drive pinion	1
2-7	0105846	Slip clutch, cpl.	1
8	0105849	Load brake cover	1
9	0105848	Hand wheel	1
13-24	0105885	Lever, cpl. (malleable iron)	1
13A-28	0108065	Lever, cpl. (rubber grip)	1
13	0105842	Lever (malleable iron)	1
28	0107731	Tube	1
Parts for Capacity 6000 kg only			
1	0105850	Drive pinion	1
2-7	0105847	Slip clutch, cpl.	1
8	0105849	Load brake cover	1
10	0107512	Crank hand wheel assy	1
13-24	0105885	Lever, cpl. (malleable iron)	1
13A-28	0108065	Lever, cpl. (rubber grip)	1
13	0105842	Lever (malleable iron)	1
28	0107731	Tube	1
Parts for Capacity 10000 kg only			
1	0105850	Drive pinion	1
2-7	0109029	Slip clutch, cpl.	1
8	0105849	Load brake cover	1
10	0107512	Crank hand wheel assy	1
13-24	0105885	Lever, cpl. (malleable iron)	1
13A-28	0108065	Lever, cpl. (rubber grip)	1
13	0105842	Lever (malleable iron)	1
28	0107731	Tube	1



Yale PUL-LIFT Ratchet Lever Hoist Mod. C/D85 Specials

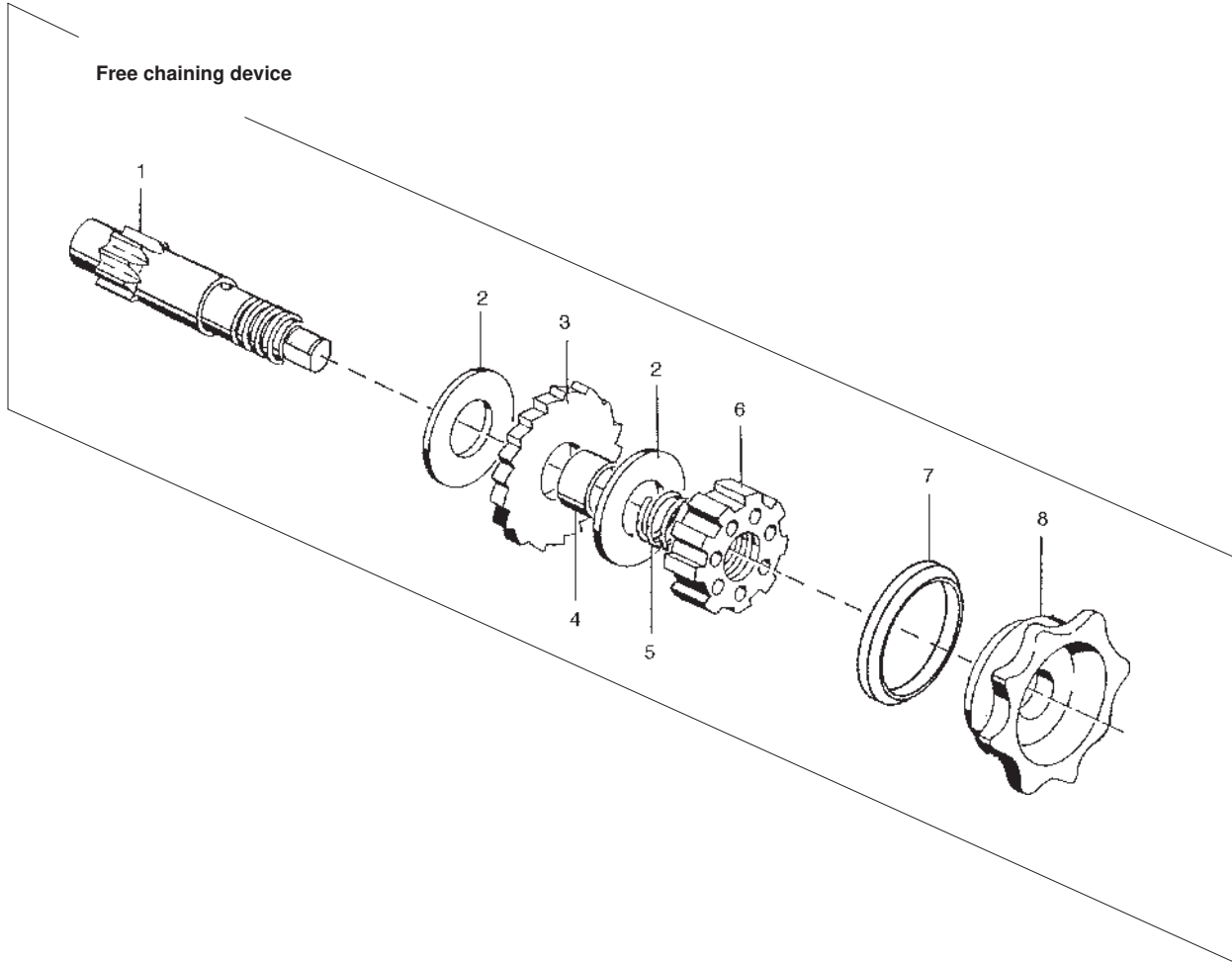

Item No.	Part No.	Description	No. off
----------	----------	-------------	---------

Parts for Capacity 1500 kg D85

Free chaining device

1	0104043	Drive pinion	1
2	0108501	Friction disc, asbestos-free	2
3	0105357	Ratchet disc	1
4	0104105	Bushing	1
5	0104047	Spring	1
6	0104044	Ratchet	1
7	0106649	Spacer	1
8	0106164	Hand wheel	1

Parts for Capacity 3000 kg D85

Free chaining device

1	0106260	Drive pinion	1
2	0108501	Friction disc, asbestos-free	2
3	0105357	Ratchet disc	1
4	0104105	Bushing	1
5	0104047	Spring	1
6	0104044	Ratchet	1
7	0106649	Spacer	1
8	0106164	Hand wheel	1

Yale PUL-LIFT Ratchet Lever Hoist Mod. C/D85



For your comments



Yale PUL-LIFT Ratchet Lever Hoist Mod. C/D85

Inspection remarks

Date of check before initial operation:

by:

Date of initial operation:

Service inspections

Date	Condition / Remarks	Repair cpl.	on	Tested by *

* Tester

Yale PUL-LIFT Ratchet Lever Hoist Mod. C/D85



EC DECLARATION OF CONFORMITY in accordance with Machinery Directive 98/37/EEC (Appendix II A)

We,

**Yale Industrial Products GmbH
D-42549 Velbert, Am Lindenkamp 31**

hereby declare, that the design, construction and commercialized execution of the below mentioned machine complies with the essential health and safety requirements of the EC Machinery Directive. The validity of this declaration will cease in case of any modification or supplement not being agreed with us previously. Furthermore, validity of this declaration will cease in case that the machine will not be operated correctly and in accordance with the operating instructions and/or not be inspected regularly.

Machine description: PUL-LIFT Ratchet lever hoist
Model D 85 with link chain
Capacity 750 - 10000 kg
Model C 85 with roller chain
Capacity 750 - 10000 kg

Machine type: Hand hoist (Lifting- and Pulling Appliance)

Serial number: from manufacturing year 11/94
(serial numbers for the individual capacities/models are registered in the production book with the remark CE-sign)

Relevant EC Directives: EC Machinery Directive 98/37/EEC

Transposed harmonised standards in particular: ISO 12100, part 1 (safety of machines)
ISO 12100, part 2 (safety of machines)
EN 349 (safety of machines)
EN 818, part 1 (round link chain)
EN 818, part 4 (round link chain)

Transposed (either complete or in extracts) national standards and technical specifications in particular: 9. GSGV
BGV D8 (Winden, Hub- und Zuggeräte)
BGV D6 (Krane)
BGR 258 (Lastaufnahmemittel)
DIN 5684, Teil 3 (Rundstahlketten, Güteklasse 8)
DIN 685, Teil 1 - 5 (Geprüfte Rundstahlketten)
DIN 8188 (Rollenketten)
DIN 15400 (Lasthaken für Hebezeuge)
DIN 15404 (Lasthaken für Hebezeuge)

Quality assurance: DIN EN ISO 9001 (Certificate Registration No.: 151)

Date / Manufacturer's authorized signature: 25.04.2005

Identification of the signee:

Dipl.-Ing. Andreas Oelmann
Manager Quality Assurance

**Quality engineered
and performance tested -
recognisably**

Yale